

*Appendix O – Tree Planting Details and Specifications Downtown Area and Regional Streets,
City of Winnipeg, May 1, 2009*



Winnipeg

Embrace the Spirit • Vivez l'esprit

Public Works Department

Parks and Open Space Division

Urban Forestry Branch

Tree Planting Details & Specifications Downtown Area and Regional Streets

May 1, 2009

This book was drafted with the help of the following:



Embrace the Spirit • Vivez l'esprit

Urban Forestry Branch

HILDERMAN
THOMAS
FRANK
CRAM

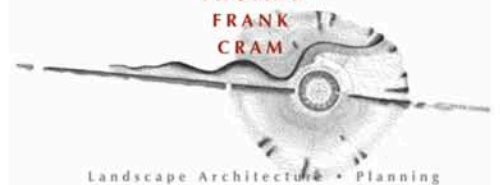

Landscape Architecture • Planning



Principles and Guidelines for Tree Planting Options

Table of Contents

1.0 PURPOSE AND OBJECTIVES

2.0 HOW AND WHERE THE GUIDELINES APPLY

- 2.1 Application of Guidelines
- 2.2 Review and Approval Process

3.0 DESIGN GUIDELINES

- 3.1 Planting Medium Volume/Quality
- 3.2 Adjacent Road Conditions
- 3.3 Sidewalk Width
- 3.4 Utility/Intersection Separation Requirements
- 3.5 Streetscape Character/Enhancements
- 3.6 Volume of Pedestrian Activity

4.0 TREE PLANTING DETAIL SUITABILITY

5.0 TREE PROTECTION DURING CONSTRUCTION

- 5.1 Tree Protection Zone
- 5.2 Tree Protection Barriers
- 5.3 Utility Construction and Engineering and Capital Construction Projects
- 5.4 Qualified Tree Consultants

APPENDIX A – SPECIFICATIONS AND DETAILS

APPENDIX B – CENTREVENTURE MANDATED AREA MAP AND 2008 REGIONAL STREETS MAP

APPENDIX C – 2006 CITY OF WINNIPEG ACCESSIBILITY DESIGN STANDARDS SECTION 4.3.17 - STREETScape

APPENDIX D – SPECIFICATIONS - DECIDUOUS TREES

1.0 PURPOSE AND OBJECTIVES

The Principles and Guidelines for Tree Planting Options for the Downtown Area and Regional Streets are based on 'Best Practices for Urban Trees' summarized in Chart 1, and consider the five tree planting options developed under the 'Tree Planting Details and Specifications for the Downtown Area and Regional Streets' report (included in Appendix A). In addition, these guidelines incorporate review and input from the following City of Winnipeg Departments and Public Utilities:

Public Works Department

- Urban Forestry Branch
- Parks and Open Space Division
- Transportation Engineering Division
- Streets Maintenance Division
- Transportation Division

Planning, Property and Development Department

- Parks, Riverbanks and Community Initiatives
- Downtown Planning
- Universal Design

Water and Waste Department

- Water and Waste Engineering

Public Utilities

- Manitoba Hydro – Hydro
- Manitoba Hydro – Gas
- MTS

The Design Guidelines are structured around the seven principles and objectives listed below:

- (a) Maximize suitable usable soil volume within a reasonable cost range per cubic of soil.
- (b) Design plantings suitable to adjacent road and sidewalk width and speed limit conditions
- (c) Consider minimum snow clearing setback and separation recommendations.
- (d) Consider minimum Winnipeg Accessibility Design Standards for clear path of travel.
- (e) Consider minimum horizontal separations and depth of cover requirements for all utilities.
- (f) Respect the existing or designed Streetscape context.
- (g) Ensure direct, comfortable and safe pedestrian routes.

Before planning and installing street tree plantings in the Downtown and Regional Streets, a qualified tree consultant must be engaged. Qualified tree consultants include (i) an arborist certified by the International Society of Arboriculture (ISA) who has a diploma (minimum) in arboriculture or urban forestry; and (ii) a landscape architect who is a member in good standing of the Manitoba Association of Landscape Architects. These design guidelines and the suitability of the five tree planting options must be considered by the project's qualified tree consultants.

Practice / Issue	No. of other jurisdictions that address issue	Common Practice	Best Practice
Species Selection	Many	Jurisdictions provide list of suitable species	Create species list for various site conditions - boulevards, high salt areas, under wires, etc. Develop diversity guidelines to discourage monoculture plantings. Match size, branching height, leaf density and other factors to site requirements.
Planting Location	Many	Planting location prescribed in relation to street edges, buildings, overhead lines, signs, utilities, etc	Locate tree in area of greatest volume of suitable soil while meeting other safety and infrastructure concerns. Be strategic in selecting planting spot rather than adhering to rigid spacing. Setback from road for reduced salt damage.
Excavation Technique	Many	Excavation depth based on height of root ball. Excavation width typically 300mm from edge of root ball	Create broad, shallow pit to improve root growth. In developed areas use hydro excavator to avoid damaging existing roots and utilities. Otherwise use backhoe or shovel - avoid auger or tree spade.
Planting Technique	Many	Plant tree at grade or slightly higher. Partially unwrap burlap wrap/ wire basket.	Remove ALL burlap and wire basket once root ball is in place. Adjust roots to prevent root circling/ girdling
Soil Type/ Suitability	Moderate- Many	Soil excavated from hole often used for backfill. Some jurisdictions specify a backfill mixture, typically clean topsoil and organics	Backfill is blended to meet demands of local conditions, specifically formulated to support tree growth. Areas of high salt contamination may wish to increase sand to permit soil flushing.
Soil Volume- Softscape	Few	Minimal attention paid to soil volume beyond the planting pit. Soil is often compacted/ degraded.	Excavate trenches and replace with improved backfill.- e.g. elm allé at The Forks, oak planting at Russell Building, University of Manitoba.
Soil Volume- Hardscape	Few-Moderate	Tree vault with tree grate still commonly used. Increasing use of structural soil.	Silva Cell/suspended sidewalks provide greatest soil volume. Research is unclear on long term efficacy of structural soil. If structural soil is specified, develop blend for local use. Large volume / continuous tree vaults appropriate for some areas. See Guidelines.
Root Egress	Few	Root egress is not usually considered in specifications. Linked to location of planting.	Plan for roots to access suitable soil. Use structural soil and root pathways to permit roots to pass under sidewalks or infiltrate soils of high compaction- e.g. Old St. Vital streetscape.
Mulch	Many	Mulch applied to tree pit 50-100mm in depth. Mulch is not applied near stem. Organic mulches are used more often than inorganic.	Mulch depth should not exceed 100 mm. Keep mulch away from stem. Maintain mulch to discourage trunk damage from string trimmers.
Irrigation	Few	Automatic irrigation not usually specified. Requires dedicated staff and ongoing maintenance and monitoring.	Bubblers and popups provide visible evidence when working properly, but not as efficient as drip. If Silva Cells are used, irrigation lines can remain on soil surface. Areas of high salt contamination would benefit from irrigation.

Chart I: Review of Common and Best Practices for Urban Tree Planting
part 1 of 2

Practice / Issue	No. of other jurisdictions that address issue	Common Practice	Best Practice
Fertilizing	Moderate	Fertilize at the time of planting.	First test then fertilize only if there is a deficiency. Avoid use of high nitrogen fertilizers in late summer and in areas of potential salt contamination.
Staking	Many	Staking is specified by most jurisdictions.	Staking is not recommended unless in high wind sites and slopes. Trees adjust to wind movement. Wires may girdle tree if not removed when tree is established. Tree guards are preferred in urban situations.
Aeration	Few	Soil aeration is not usually specified.	Aeration should not be necessary if trees have suitable soil. Vertical mulching and aeration pipes may be installed under paving.
Root Barriers	Few	Root barriers are not usually specified.	Place root barrier away (120mm) from structure to be protected so roots do not impact curb/ sidewalk as they grow. Ensure adequate soil volume if used.
Drainage	Moderate	Tree vault drawings/ specifications include drainage pipe to catch basin.	If road has no subdrainage, alternate drainage must be provided in all plantings. Methods include free draining stone, perforated pipe connected to storm water system, and sumps below planting site.
Protection from Mechanical Damage	Moderate- Many	Specifications usually address protection from construction activities. Tree guards/ fences not usually specified.	Critical rooting zone should be protected during construction by the use of temporary fencing/flagging tape. Tree guards/fences can reduce mechanical damage from pedestrians and snowplows - tree guards can be designed to serve as bike racks. Raised planters and curbed tree pits can provide some protection. Hydro excavation and boring can be alternatives to trenching/ cutting of roots for utility installation/ maintenance.
Protection from Salt Damage	Few	Selection of salt tolerant species.	Species selection. Reduce winter speed limit to reduce roadway splash/ salt plume. Use irrigation to flush soil in fall and spring. Install raised planters/ tree pit collars to reduce inflow of salt runoff. Designate important treed corridors for alternate applications (e.g. calcium magnesium acetate, or calcium chloride). Treat salt damage soils with gypsum (calcium sulfate). Incorporate organics into soil to maintain soil structure. Avoid piling salt contaminated soil around trees. Wrap crown or install fabric fences to reduce salt splash contamination.
Maintenance (Establishment Phase)	Many	Regular water during first 2- 3 years. Prune dead and damaged limbs at the time of planting. Weed pits and maintain mulch.	Typically 5-10 gallons of water/ week for first growing season. Treegators used to achieve deeper soaking. Do not prune crown at time of planting to "compensate" for root loss. Prune only for pedestrian clearance.
Maintenance (Long Term)	Few	Specifications rarely address long term maintenance.	Regular pruning. Pest and disease monitoring/ control. Protection from mechanical damage. Irrigation. Maintain soil health/ minimize salt contamination.

Chart I: Review of Common and Best Practices for Urban Tree Planting
part 2 of 2

2.0 HOW AND WHERE THE GUIDELINES APPLY

2.1 Application of Guidelines

The 'Design Guidelines are to be used to determine which tree planting option is best suited for each site and situation. These guidelines apply to the design, review and approval of all street tree plantings for the downtown area and regional streets including all Image Routes and Business Improvement Zones. The downtown area is defined as the lands designated as the CentreVenture Mandated Area. The Council adopted list of regional streets is available from Public Works. The CentreVenture Mandated Area map and 2008 Regional Streets map have been included in Appendix B for reference

The guidelines will apply to the evaluation of tree planting design alternatives in Capital Street and Streetscape Construction Projects, Major Street and Streetscape Renovation Projects, Downtown Enhancement, Image Route and BIZ Enhancements, Sidewalk Replacement Program and Major Tree Re-planting Projects. They are intended to be read together with 'Tree Planting Details and Specifications for the Downtown Area and Regional Streets', other applicable Forestry standards, City of Winnipeg Accessibility Design Standards (WADS), and other applicable City standards, by-laws, policies, and guidelines. The guidelines address the placement, detailed design and selection of the most suitable tree planting option.

2.2 Review and Approval Process

The review and approval process for street tree planting in the downtown area and regional street is as follows:

- (i) Meetings for review and approval of conceptual design with:
 - (a) Urban Forestry Branch – City Forester
 - (b) Urban Design Advisory Committee – Senior Urban Designer (Downtown Planning Branch, Planning, Property and Development). Downtown projects only.
 - (c) Parks, Open Space and Urban Initiatives – Senior Urban Designer (Parks, Riverbanks and Community Initiatives Branch, Planning, Property and Development
 - (d) Applicable Business Improvement Zone – Senior Urban Designer (Parks, Riverbanks and Community Initiatives Branch, Planning, Property and Development). In Business Improvement Zones only.
 - (e) Universal Design Co-ordinator – Parks, Riverbanks and Community Initiatives Branch, Planning, Property and Development
 - (f) Streets Projects Engineer – Transportation Division, Public Works
 - (g) Traffic Management Engineer – Transportation Division, Public Works
 - (h) Design and Construction Engineer – Engineering Division, Water and Waste
- (ii) Submission of Construction Drawings for Review and Approval:
 - (a) Urban Forestry Branch – City Forester (2 weeks)
 - (b) UGS Technician III – Underground Structures Branch, Public Works (6 weeks)
 - (c) Development Permit (where applicable) – 986-8113 – 6 weeks

3.0 DESIGN GUIDELINES

The Design Guidelines section is organized into six sub-sections:

- 3.1 Planting Medium Volume/Quality
- 3.2 Adjacent Road Conditions
- 3.3 Sidewalk Width
- 3.4 Utility/Intersection Separation Requirements
- 3.5 Streetscape Character/Enhancements
- 3.6 Volume of Pedestrian Traffic

Each sub-section provides a range of strategies and specific measures intended to improve street tree planting design. Designers are encouraged to generate site specific solutions that meet the intent of the Guidelines, using one of the four hardscape tree planting options or the turf tree planting detail (Appendix A). To aid in this process, Section 4.0 includes Chart 2 which applies the following guidelines to determine which hardscape tree planting option is best suited for each site and situation.

The recommended setbacks to trees and tree infrastructure, identified in Section 3.2 below, are intended for use as general guidelines to assist the designer. Factors such as the presence of existing trees or other fixed objects in the right-of-way, the presence of curves in the roadway, operating speed and collision history should be considered when determining setback requirements. All setbacks in the Downtown Area and on Regional Streets are subject to review by the Forestry and Transportation Engineering Divisions.

3.1 Planting Medium Volume/Quality

- 3.1.1 Maximize planting medium (refer to Specification E6 included in Appendix A) volume. Minimum range 8.5 cu.m. (300 cu.ft.) to 12.75 cu.m. (450 cu.ft.)

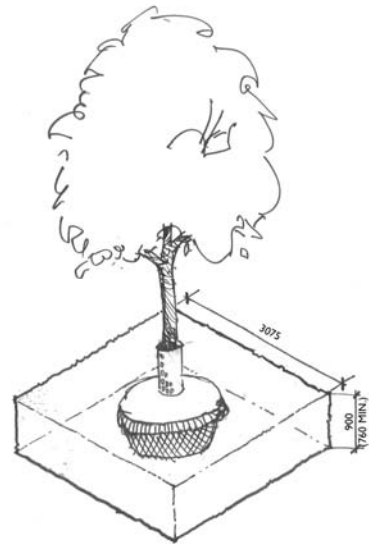

- 3.1.2 Minimum two trees together in shared minimum planting medium volume of 17.0 cu.m. (600 cu.ft.) to 25.5 cu.m. (900 cu.ft.)

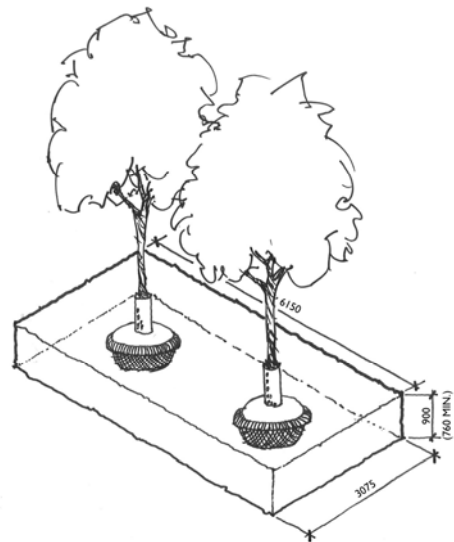

- 3.1.3 Optimal planting medium depth 900mm (36in.). Minimum planting medium depth of 760mm (30in.) will be accepted where 900mm is not feasible.

- 3.1.4 Soil modifications based on in situ soil test recommendations (clay content, permeability, nutrient levels, pH level), may be required.
- 3.1.5 Alternative drainage system acceptable to the City of Winnipeg is required if water does not drain out of the in situ soil surrounding the tree pit.

3.2 Adjacent Road Conditions

- 3.2.1 On streets with a posted speed limit of 50km/h, a 1.2m setback is recommended to centre of tree or edge of raised planter on roadways four (4) lanes or less (to facilitate snow storage and clearing operations).

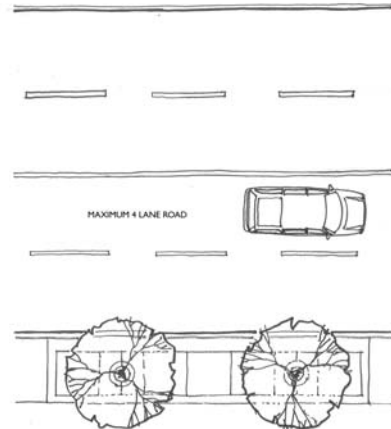

- 3.2.2 On streets with a posted speed limit of 50km/h, a 1.5m setback is recommended to centre of tree or edge of raised planter on roadways more than four (4) lanes (to facilitate snow storage and clearing operations).

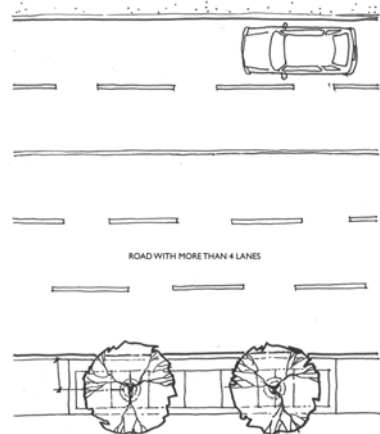

- 3.2.3 A minimum boulevard setback of 0.8m to centre of tree or edge of raised planter shall be permitted in the downtown area. Trees should be no closer to the street than other fixed object infrastructure such as hydro poles and fire hydrants. Maximizing the setback distance of trees from streets is always desirable, so this minimum setback should be increased whenever possible.

- 3.2.4 On streets with a posted speed limit of 60km/h
 - (a) with a limited boulevard width, street trees should be reviewed on a case by case basis with Forestry and the Transportation Division. Trees should be set back as far as possible from the back of curb.
 - (b) with wide boulevards, a 3.35m setback for street trees from back of curb is desired.

3.2.5 'Americans with Disabilities Act' (ADA) compliant tree grates or tree vault cover required where street parking is permitted. Raised planters must be located to permit WADS compliant access to streetside parking.

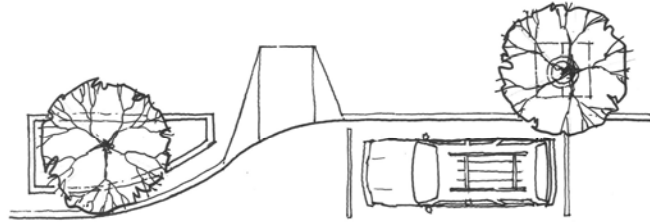

3.2.6 Trees are permitted in medians that are a minimum of five metres wide (as measured from back of curb to back of curb). Medians narrower than five metres will be considered for tree planting on streets with 50km/h and 60km/h posted speed limits if an appropriate traffic barrier (example – raised safety median or safety curb 330mm high) is installed between the edge of the roadway and the trees.

3.2.7 On streets with higher posted speeds (70km/h or higher) setbacks from back of curb should be in the order of six metres due to salt spray concerns and the desire to provide a minimum clear zone for vehicles that may leave the roadway.

3.3 Sidewalk Width

3.3.1 Planting locations downtown must comply with minimum recommendations for snow clearing setback (0.8m minimum) minimum requirements for clear path of travel (1.5m minimum) and WADS requirement for two contrasting surface bands (0.4m minimum). Total minimum sidewalk width required for tree planting in the downtown area is 2.95m. ADA compliant tree grates/vault covers (with integrated contrasting surface band) will be required for sidewalks less than 3.5m wide.

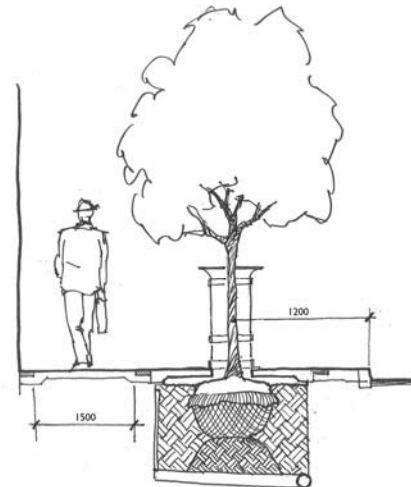

3.3.2 Outside the downtown area, tree planting is not advised where sidewalk width is less than 3.35m. Sidewalks less than 3.35m wide have insufficient space to meet WADS requirements (1.5m clear path of travel plus 0.4m for two contrasting surface bands), half the width of the minimum tree pavement opening (0.25m) and minimum snow clearing setback recommendations (1.2m). ADA compliant tree grates/vault covers (with

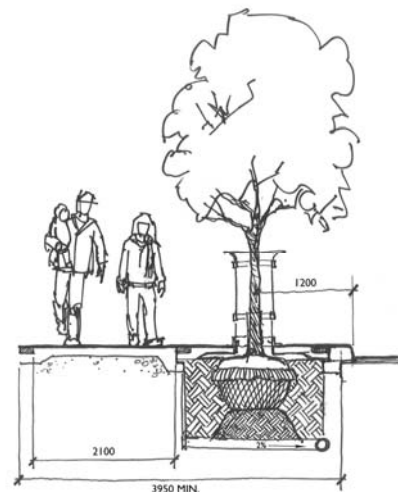

integrated contrasting surface band) will be required for sidewalks less than 3.9m wide.

3.3.3 In areas of low pedestrian activity in the downtown, tree planting could be considered where sidewalk width is less than 3.95m with building at the property line, if permission is received from City of Winnipeg Universal Design Consultant (Judy Redmond – 986-2131) to reduce the required clear path of travel width and/or from City of Winnipeg Streets Maintenance Division (Gary Pekrul – 986-3165) to reduce the recommended snow clearing setback.

3.3.4 Planting is permitted at back of sidewalk where sidewalk width is greater than 3.45m with softscape at property line. ADA compliant tree grates/vault covers will be required for sidewalks less than 3.65m wide.

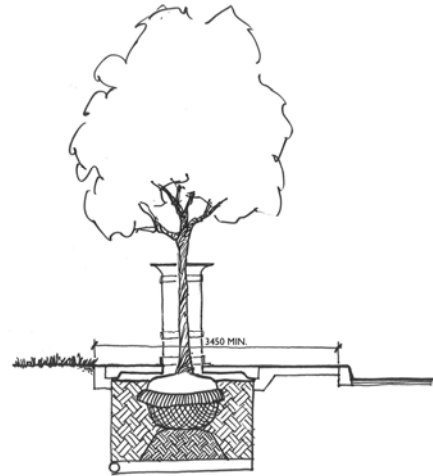

3.4 Utility Separation Requirements

3.4.1 Gas¹

- (a) A minimum horizontal separation of 1.0m must be maintained between the edge of the tree excavation and any existing natural gas main. If this minimum separation cannot be maintained, contact Manitoba Hydro to discuss site specific options.
- (b) A minimum depth of cover shall be maintained in all areas where equipment will be crossing, travelling or compacting over natural gas mains. The required depths of cover are:
 - 900mm over high pressure gas mains
 - 600mm over distribution mains.
- (c) If equipment must cross, travel, or compact over a natural gas main with less than the minimum depth of cover, earth bridging or steel plates shall be placed over the main and extend a

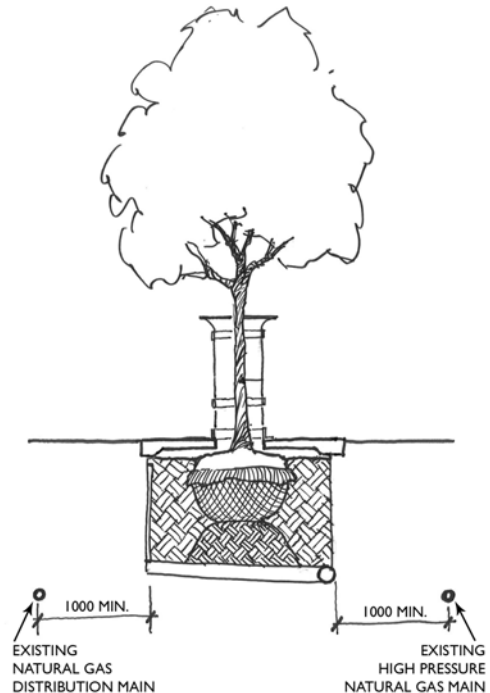

¹ Requirements provided by Manitoba Hydro (Gas)

minimum of 1.0 m on either side at each crossing location.

- (d) All natural gas pipelines and service lines must be properly located and marked by Manitoba Hydro personnel. Construction operations are not to commence unless these conditions are adhered to. Prior to tree planting, Manitoba Hydro's Call before you dig program at (204) 480-1212 should be contacted.

3.4.2 Hydro²

- (a) A minimum horizontal separation of 1.0m must be maintained between the edge of the tree excavation and any existing underground electrical distribution (ie. Underground cables, ducts, etc.)
- (b) A minimum horizontal separation of 3.0m must be maintained between the edge of tree excavation and any existing electrical manholes.
- (c) A minimum horizontal separation of 3.0m must be maintained between the centre of the tree and any street light or hydro pole.
- (d) A minimum depth of cover of 300mm should be provided between the bottom of the tree vault and any underground distribution plant.
- (e) All electrical distribution must be properly located and marked by Manitoba Hydro personnel. Construction operations are not to commence unless these conditions are adhered to. Prior to tree planting, Manitoba Hydro's Call before you dig program at (204) 480-1212 should be contacted.

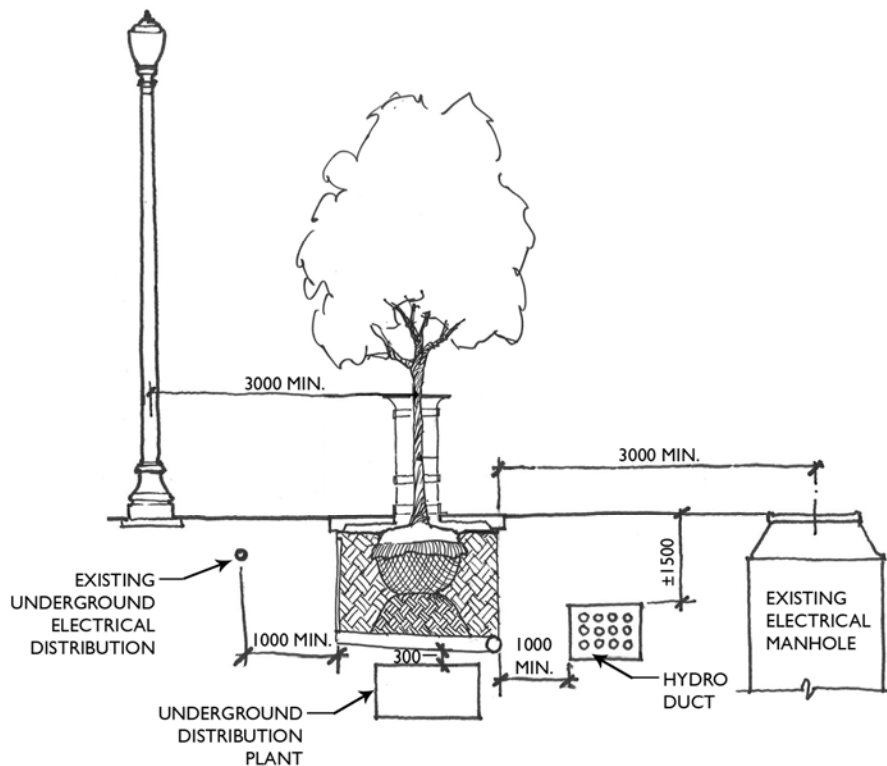

² Requirements provided by Manitoba Hydro (Hydro)

3.4.3 MTS³/Shaw/Fibre Optics

- (a) A minimum horizontal separation of 1.0m must be maintained between the edge of the tree excavation and any existing MTS/Shaw/Fibre Optic line, if this minimum separation cannot be maintained, contact MTS/Shaw/Fibre Optic provider to discuss site specific options.
- (b) A minimum depth of cover shall be maintained in all areas where equipment will be crossing, travelling or compacting over MTS/Shaw/Fibre Optic lines. The required depth of cover is 600mm.
- (c) If equipment must cross, travel, or compact over a MTS/Shaw/Fibre Optic line with less than the minimum depth of cover, earth bridging or steel plates shall be placed over the main and extend a minimum of 1.0 m on either side at each crossing location.
- (d) All MTS/Shaw/Fibre Optic lines must be properly located and marked by applicable personnel. Construction operations are not to commence unless these conditions are adhered to.

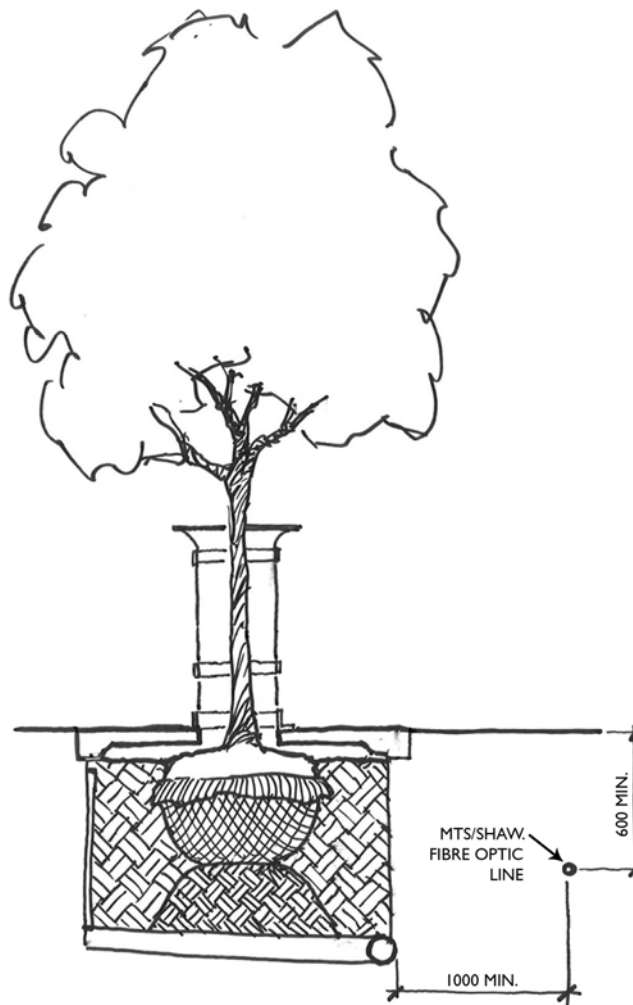

³ Requirements to be confirmed by MTS

3.4.4 Watermains, Waste Water Sewer, Land Drainage Sewer

- (a) A minimum horizontal separation of 3.0m must be maintained between the centre of the tree and any existing fire hydrant.

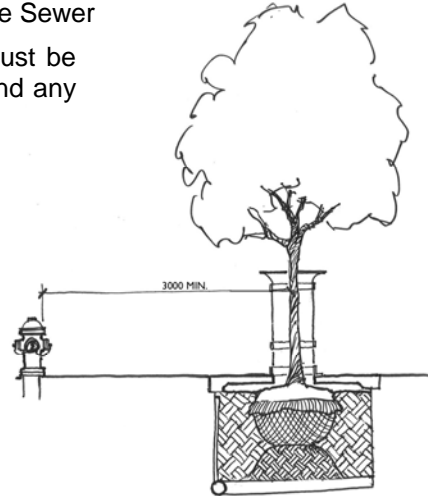

3.4.5 Intersections

- (a) Trees shall be planted at a minimum distance from the nearside back of curb for the following intersections:
 - (a) Street intersections – 6.0m
 - (b) Backlane intersections – 3.0m
 - (c) Private approaches – 1.5m

3.5 Streetscape Character

3.5.1 Planting design must respect existing or planned streetscape context.

3.5.2 When trees are placed at back of curb, locate within 'Street element zone' (as defined in WADS 4.3.17)

3.5.3 When trees are placed at the back of sidewalk, define edge of opening using 'contrasting surface' (as defined in WADS 4.3.17)

3.5.4 When planting in the vicinity of existing trees, hydro excavate to expose existing root systems and thereby minimize damage. Refer to section 5.0.

3.6 Volume of Pedestrian Traffic.

3.6.1 Comply with 2006 City of Winnipeg Accessibility Design Standards (WADS) Section 4.3.17 - Streetscape (Appendix C)

4.0 TREE PLANTING DETAIL SUITABILITY

Based on the 'Best Practices for Urban Trees' outlined in Chart 1 and a review of the performance of existing tree planting details in downtown Winnipeg, specifications and details were prepared for four preferred hardscape tree planting options:

- (a) Silva-Cells
- (b) Vault
- (c) Raised Planter
- (d) Structural Soil

These tree planting options are outlined in the 'Tree Planting Details and Specifications for Downtown Area and Regional Streets' report which is included in Appendix A.

The key advantages, disadvantages and application of each of the four hardscape tree planting options is summarized below.

- (a) Silva-Cells – A proprietary product by DeepRoot Partners, consisting of stackable polyethylene and fibreglass frames and decks designed to be filled with soil for tree rooting and support vehicle-loaded (AASHTO H-20) sidewalk pavements.

Key Advantages:

- Unlimited volume – System allows for very large soil volumes under pavement.
- Modular – Soil volume can take a variety of shapes.
- Airspace in cells provides good aeration.
- Completely subterranean system, offers flexibility in paving cover appearance and materials.
- High strength H -20 loading.
- Protects soil from compaction, allows flexibility in soil specification.

Key Disadvantages:

- Relatively expensive.
- One supplier, requires shipping.
- Vulnerable to damage during utility repairs, complicated to repair.
- Requires diligent record-keeping and record-sharing to avoid damage from subsequent construction activities.

Application:

- Best used in high profile sites where very large trees are required, and where very large soil volumes can be accommodated with minimal underground utility conflict.

- (b) Vaults – Cast-in-place concrete tree well (poured as separate curb or integral with sidewalk) designed to support a series of precast concrete sidewalk panels and tree vault covers which span an enlarged tree planting medium volume and support standard snow clearing vehicle loading.

Key Advantages:

- Relatively low cost per cubic meter of soil.
- Suitable for most sidewalk widths, high volume of pedestrian activity and intensive streetscape development areas.
- Protects soil from compaction and salt spray.
- Sidewalk panels can be removed for utility repairs.

Key Disadvantages:

- Requires an irrigation system.
- Requires tree guards to protect trees from mechanical damage.

Application:

- Good for most locations as long as trees are irrigated.

- (c) Raised Planters – Standard City of Winnipeg tree planting soil medium is contained partially above grade using minimum 450mm height, 1500 mm inside width insulated planter walls designed to suit the streetscape context.

Key Advantages:

- Reduces depth of soil required below sidewalk grade.
- Protects trees from mechanical damage and salt spray.
- Protects soil from compaction and salt spray.

Key Disadvantages:

- Soil volume limited by competition with other surface streetscape requirements.
- Cost per cubic meter of soil is relatively high.
- Planter vulnerable to damage during utility repairs and snow storage and removal operations.
- Barrier between street parking and clear path of travel.
- Wide boulevard required to maintain clear path of travel and snow storage zone requirements.

Application:

- Best used in wide intensively used streetscape zones and where shallow, buried utilities limit the use of other tree planting options.

- (d) Structural Soil – A porous mixture of quality aggregate and clay loam formulated to support sidewalk pavement while providing space for tree roots, developed by Cornell University's Urban Horticulture Institute. Various jurisdictions have developed their own versions of the Cornell's CU Soil™, but generally all combine clay loam with angular, carefully-sized aggregate that when compacted, maintains pore spaces for root penetration, air and water. A tackifying agent is added to the mix to bind the soil to the aggregate.

Key Advantages:

- Once mixed, installation is similar to establishing base for standard sidewalk paving.
- Facilities repair; suitable for use around shallow utilities.

Key Disadvantages:

- Low volume of soil available to support the tree.
- Need for precise control of ingredients and proportions.
- Testing procedures are non-standard and costly.
- Moisture sensitive mixing and placing is weather dependent; needs to be mixed and used in small batches.
- Lack of research on long-term viability of structural soil plantings.

Application:

- Best used in 'break out' zones (i.e., providing a passageway for the roots of curbside trees to greenspace with higher soil volume at the back of the sidewalk). Also well suited for plantings near shallow utility lines.

Chart 2: 'Hardscape Tree Planting Detail Suitability', applies the principles and guidelines outlined in Sections 1.0 and 3.0 of this report to determine which tree planting option is best suited for each hardscape site and situation. In turf areas, refer to Detail 5 'Tree Planting in Turf Boulevards/Medians' in Appendix A.

	Silva-cell		Vault	Raised Planter	Structural Soil	
	With Grate	No Grate	Cover Required	No Grate	With Grate	No Grate
Approx. cost per tree	High	High	Medium	Medium	Medium	Low
Cost per m3 of soil	High	High	Low	High	Medium	Medium

A Adjacent Road Conditions

4 lanes or less in right-of-way	●	●	●	⊙	●	●
More than four lanes in R.O.W.	●	●	●	⊙	●	●
Speed limit 60km/h or less	●	●	●	●	●	●
Speed limit >60km/h	●	○	●	⊙	●	○
On-street parking	●	○	●	⊙	●	○

B Sidewalk Width

<3.65m; building or pavement adjacent	○	○	○	○	○	○
>3.375m; softscape adjacent	●	⊙	●	○	●	⊙
3.65 - 5.3m wide sidewalk	●	●	●	○	●	●
5.3m +	●	●	●	●	●	●

C Underground Utilities

Below 1m depth	○	○	⊙	⊙	●	●
Above 1m depth	○	○	○	⊙	⊙	⊙

D Streetscape

Street furniture (lamps/ banners, etc)	⊙	⊙	●	●	●	●
Concrete pavement	●	●	●	●	●	●
Unit paving blocks	⊙	⊙	⊙	●	●	●
Existing trees at grade	⊙	⊙	⊙	⊙	⊙	⊙
Curbside vendors expected	●	⊙	●	⊙	●	⊙

E Volume of Pedestrian Activity

Low	●	●	●	⊙	●	●
High (periodic or constant)	●	⊙	●	⊙	●	⊙

With Grate	No Grate	Grate Required	No Grate	With Grate	No Grate
Silva-cell		Vault	Raised Planter	Structural Soil	

- Suitable
- ⊙ Suitable in some situations
- Not suitable

Comments

Min. 1.2m setback for raised bed in downtown. Refer to Guidelines for regional streets.
1.5m setback min. for raised bed in downtown. Refer to Guidelines for regional streets.
Refer to Guidelines for regional streets.
Tree pits to be raised, covered, or set well back from the road.
Raised planters may be an obstacle. Other details are suitable with ADA-compliant grates. See Guidelines.
Insufficient clear space to meet min. soil volume guideline
Adjacent soft surfaces may be used as additional soil volume- provide root path with silva cells or structural soil. Grates required.
Raised planters may constrict sidewalk or limit snow storage
All structures can be expensive to repair after service cuts
Raised planter & structural soil are best options over shallow utilities
Coordinate pile locations with silva cells. Consider wooden seats on raised planter walls
Silva cells require 300 deep granular base under pavers; vaults need blockout for pavers
All require care in excavation and regrading
Raised planters may limit available vendor space. ADA grates expand usable surface.
Raised planters may inconvenience pedestrians
Avoid obstructing areas where large crowds may move through- eg. theatre/sports arena entrances. Uses ADA compliant grates.

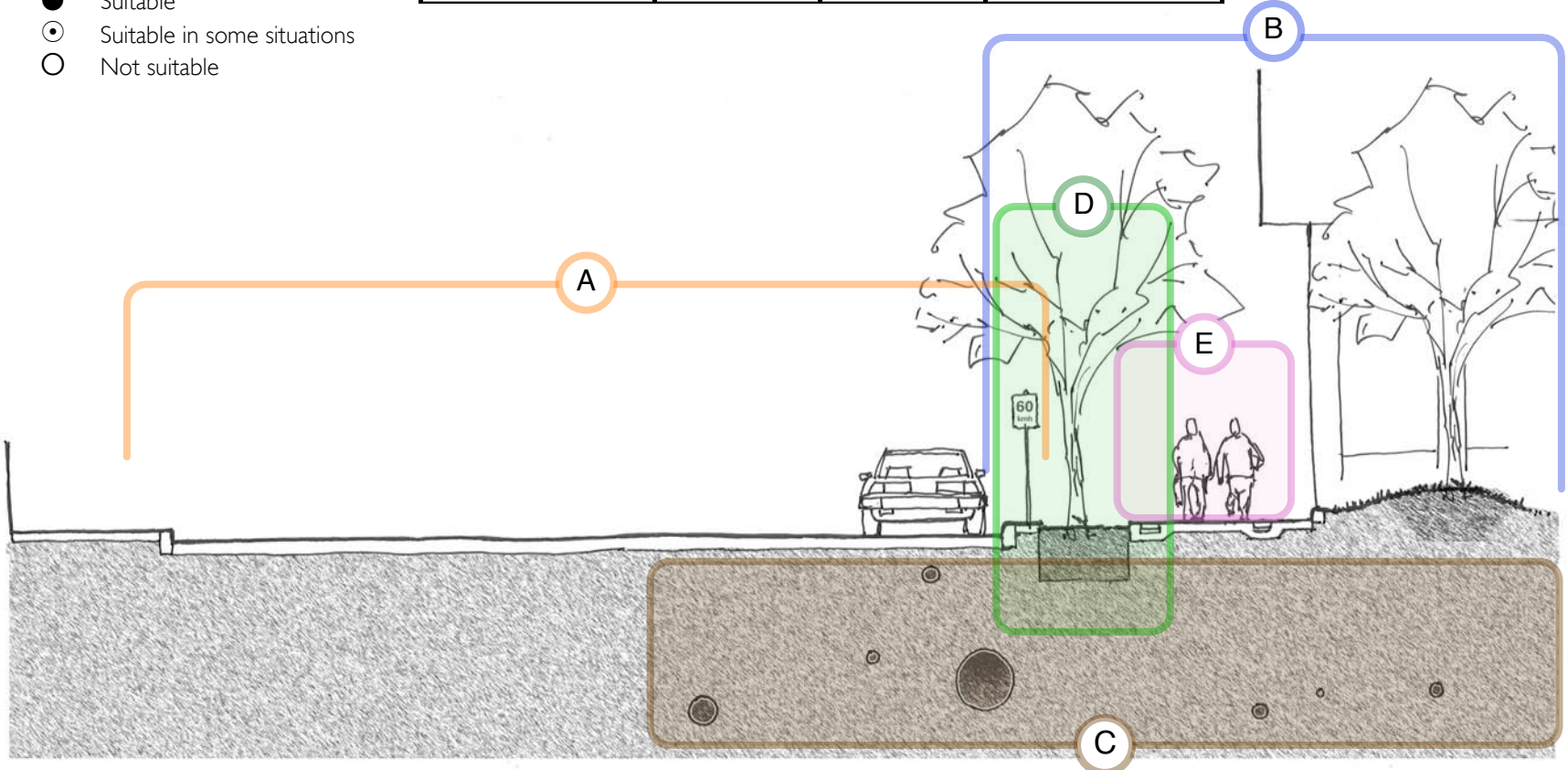

Chart 2: Hardscape Tree Planting Detail Suitability Chart
 McGowan Russell & Hilderman Thomas Frank Cram – Draft, March 23, 2008

5.0 TREE PROTECTION DURING CONSTRUCTION⁴

Construction activities near trees may result in injury to the trunk, limbs or roots of trees causing damage or death of the tree. In order to prevent such damage:

- Trees within or adjacent to a construction area must be protected during construction by means of a barrier surrounding a “Tree Protection Zone” (TPZ) as outlined in Sections 5.1 and 5.2 of this policy.
- Activities which are likely to injure or destroy the tree are not permitted within the TPZ.
- Tree pruning or root pruning of City of Winnipeg owned trees may only be done by a Contractor approved by the project’s Qualified Tree Consultant (Refer to 5.4) or Urban Forestry Branch.
- No objects may be attached to trees protected by City of Winnipeg by-laws without written authorization by the City of Winnipeg.
- No City of Winnipeg tree or tree protected by a City of Winnipeg by-law may be removed without the written permission of the City of Winnipeg.

5.1 Tree Protection Zone

The following is a chart showing optimal distances for determining a tree protection zone.⁵ Some site conditions may dictate the need for a smaller TPZ. The City of Winnipeg Urban Forestry Branch must be notified in these instances. Forestry will determine if the smaller TPZ is acceptable in the specific circumstance and advise of any additional tree protection or removal requirements.

Table 1 – Tree Protection Zones

Trunk Diameter (DBH) ⁶	Minimum Protection Distances Required ⁷
<10 cm	2.0m
11-40cm	2.4m
41-50cm	3.0m
51-60cm	3.6m
61-70cm	4.2m
71-80cm	4.8m
81-90cm	5.4m
91-100cm+	6.0m

5.2 Tree Protection Barriers

Trees within tree protection zones shall be protected by means of a “tree protection barrier” meeting the following specifications:

- The required barrier is a 1.2 metre (4 ft) high orange plastic web snow fencing on 2” x 4” frame or as directed by the City of Winnipeg Urban Forestry Branch in accordance with City of Winnipeg Protection of Existing Tree Specifications. The barrier can be lowered around branches lower than 1.2 metres (4 ft). The barrier location can be adjusted to align with curbs and edges at clear path of travel zones.
- Tree strapping material will be installed on individual trees, in accordance with CW1140, where Work will be completed within the TPZ.

⁴ Based on - Parks and Open Space, City of Oakville, Ontario. Tree Protection Specifications for Construction Near Trees, 2008

⁵ The roots of a tree can extend from the trunk to approximately 2-3 times the distance of the drip line.

⁶ Diameter at breast height (DBH) measurement of tree trunk taken at 1.4 metres above ground.

⁷ Tree Protection Zone distances are to be measured from the outside edge of the tree base towards the drip line and may be limited by an existing paved surface, provided the existing paved surface remains intact throughout the construction work.

- Tree protection barriers are to be erected prior to the commencement of any construction or grading activities on the site and are to remain in place throughout the entire duration of the project. The applicant shall notify the City of Winnipeg prior to commencing any construction activities to confirm that the tree protection barriers are in place.
- All supports and bracing used to safely secure the barrier should be located outside the TPZ. All supports and bracing should minimize damage to roots.
- No grade change, storage of materials or equipment is permitted within this area. The tree protection barrier must not be removed without the written authorization of the City of Winnipeg.

5.3 Utility Construction and Engineering and Capital Construction Projects

It is recognized that there are cases where trees are growing overtop existing utilities or beside capital infrastructure. While the guidelines in this section still apply, in these cases some modification to Table 1 in addition to root pruning may be permitted provided non-open trench methods of construction are employed (as defined in CW2110 and CW2130).

Root Pruning will be required to be done under the direction of - and along with - written sign-off by the Project's Qualified Tree Consultant (Refer to 5.4). The objective is to avoid severance of anchor roots, which provide upright support for trees and minimize damage to the tree.

Above ground clearance for overhanging branches in the work zone must be anticipated. The utility or its consultant is required to have a Forestry approved tree service raise the crown of all branches to provide adequate clearance for construction equipment.

5.4 Qualified Tree Consultants

- (i) An arborist certified by the International Society of Arboriculture (ISA) who has a diploma (minimum) in arboriculture or urban forestry; and
- (ii) A landscape architect who is a member in good standing of the Manitoba Association of Landscape Architects

Appendix A

Table of Contents

Part 1: Guide Specifications

E1. SILVA CELLS	2
E2. RAISED TREE PLANTERS	12
E3. TREE VAULTS	15
E4. STRUCTURAL SOIL	18
E5. MICRO IRRIGATION SYSTEM REQUIREMENTS	24
E6. STREET TREE PLANTING MEDIUM	29
E7. TREE PLANTING – DOWNTOWN AND REGIONAL STREETS	31
E8. TREE GRATES AND GUARDS	38
E9. LONG TERM MAINTENANCE OF NEW TREE PLANTINGS	40

Part 2: Guide Details

Detail F1: Tree Planting using Silva Cells	
Detail F2: Tree Planting in Raised Concrete Planter	
Detail F3: Tree Planting in Tree Vault	
Detail F4: Tree Planting using Structural Soil	
Detail F5: Tree Planting – Downtown and Regional Streets	
Detail F6: Standard Tree Guard	

E1. SILVA CELLS

1. DESCRIPTION

1.1 General

- .1 This Specification shall cover the supply and installation of DeepRoot "Silva Cell" system for tree planting on downtown and regional streets, including Silva Cells, geotextile, geogrid, granular sub-base, backfill, drainage system, planting medium, mulch, and granular base for paving.

1.2 Referenced Standard & Draft Construction Specifications

- .1 CW 1120 – Existing Services, Utilities and Structures
- .2 CW 3110 – Sub-grade, Sub-base and Base Course Construction
- .3 CW 3120 – Installation of Sub Drains
- .4 CW 3130 – Supply and Installation of Geotextile Fabrics
- .5 CW 3170 – Earthwork and Grading
- .6 CW 3325 – Portland Cement Concrete Sidewalk
- .7 CW 3330 – Installation of Interlocking Pavement Stones
- .8 E5 – Micro Irrigation System Requirements
- .9 E6 – Street Tree Planting Medium
- .10 E7 – Tree Planting – Downtown and Regional Streets
- .11 E8 – Tree Grates and Guards

1.3 Referenced Details

- .1 F1 – Tree Planting Using Silva Cells
- .2 F5 – Tree Planting – Downtown and Regional Streets
- .3 F6 – Standard Tree Guard

2. MATERIALS

2.1 Silva Cells

- .1 Silva Cell Frames: 400mm x 600mm x 1200mm. Manufacturer: DeepRoot Partners, L.P. (Deep Root); 530 Washington Street, San Francisco, CA 94111; 415.781.9700; 800.458.7668; fax 415.781.0191; www.deeproooot.com.
- .2 Silva Cell Deck: 5cm x 600mm x 1200mm. Deck to include manufactured installed galvanized steel tubes.

- .3 Silva Cell Strongback: 400mm x 600mm x 150mm modified Silva Cell Frame units designed to stiffen and align the frames as planting soil and backfill material is placed. Strongbacks are to be removed prior to placing decks. They are to be reused as the work progresses.

2.2 Anchors and Hardware

- .1 Silva Cell Deck Screws: Manufacturer's supplied stainless steel screws to attach decks to frames.
- .2 Anchoring Spikes: 250mm long X 8mm diameter, spiral, galvanized timber spikes. Utilize 4 nails in each frame on the first layer of Silva Cells to anchor the frames to the aggregate subbase.

2.3 Sub Drain

- .1 To City of Winnipeg Specification CW 3120 - Installation of Sub Drains.

2.4 Inspection Riser and Cap

- .1 Inspection riser shall consist of a rigid, Schedule 40 non-perforated PVC pipe, 63.5mm in diameter. Cut slots in the bottom to allow water access for inspection risers that extend to the sub base aggregate.
- .2 Cap shall be PVC solid threaded cleanout or removable inlet grate designed to fit standard PVC schedule 40 pipe fittings.

2.5 Geogrid

- .1 Miragrid 2XT as manufactured by Ten Cate Nicolon, Norcross, GA, or approved equal, www.tcmirafi.com

2.6 Geotextile

- .1 Non-woven separation/reinforced fabric as per CW 3130, or approved alternate with the following properties:

Grab tensile strength:	0.9 kN
Grab tensile elongation:	50%
Mullen burst strength:	2.618 kPa
Puncture strength:	.58 kN
Apparent opening size:	0.180 mm
Water flow rate:	3866 l/min/m ²

2.7 Root Barrier

- .1 Nillex DeepRoot UB -18 or approved equal.

2.8 Granular Base Course (Below Cell Frame)

- .1 Crushed Gravel Base Course material in accordance with CW3110. Crushed limestone is not acceptable.

2.9 Granular Base Course (Above Cell Deck)

1. Crushed Gravel Base Course material in accordance with CW3110. Crushed limestone is not acceptable.

2.10 Backfill Material (Adjacent to Silva Cells)

- .1 In accordance with Specification CW2030, Backfill class as determined by Contract Administrator.

2.11 Street Tree Planting Medium

- .1 Refer to Specification E6: Street Tree Planting Medium.

2.12 Mulch

- .1 Refer to Specification E7: Tree Planting – Downtown and Regional Streets.
- .2 Or approved alternate.

2.13 Construction Mats

- .1 Mud-Traks as distributed by SEV Sales, Charlotte, NC 28216, 800 762 8267 or approved alternate. Mat strength shall be as required for the vehicle loading application.

2.14 Tree Grate

- .1 Refer to Specification E8: Tree Grates and Guards.

2.15 Tree Guard

- .1 Refer to Specification E8: Tree Grates and Guards.

3. CONSTRUCTION METHODS

3.1 Layout Approval

- .1 Prior to the start of work, layout and stake the limits of excavation and horizontal and vertical control points sufficient to install the Silva Cells, backfill and required drainage features in the correct locations.

3.2 Excavation

- .1 Excavate in accordance with Specification CW 3170, to the depths and limits indicated on the Drawings. Base of excavation shall be smooth soil, free of lumps or debris, sloped toward sub drain as indicated on the Drawings.
- .2 Do not over-excavate existing soil beside or under the limits of excavation required for the installation. If soil is over-excavated, install compactable fill material in lifts not more than 200mm deep and compact to the required density.
- .3 Confirm that the depth of the excavation is accurate to accommodate the depths and thickness of materials required throughout the extent of the excavation.

- .4 Confirm that the width and length of the excavation is a minimum of 150mm in all directions, beyond the edges of the Silva Cells.

3.3 Sub-Grade Compaction

- .1 Compact sub-grade below the Silva Cells to a minimum of 95% standard Proctor Density, in accordance with Specification CW 3170.

3.4 Installation of Geotextile Over Sub-Grade

- .1 Where adequate sub-grade compaction cannot be attained, install geotextile over the compacted sub-grade material with a minimum joint overlap of 450mm between sections of material as directed by Contract Administrator.

3.5 Installation of Sub Drains

- .1 Sub drains not required when adjacent street is equipped with curb sub drains.
- .2 Layout the location of sub drains as shown on the Drawings. Adjust the alignments to conform to the final locations of sleeves and risers. Do not locate drain lines within 150mm of the edge of any Silva Cell post. Ensure positive drainage toward intended outfalls.
- .3 Excavate a trench a minimum of 300mm wide to a depth required to provide positive drainage from the high points of the system to the outfall or connection point to storm sewer. Eliminate dips or rises that will trap water. Minimum slope shall be 1%.

3.6 Installation of Inspection Risers

- .1 Install inspection risers to finish grade.
- .2 Install manufacturer's PVC solid "T's," elbows, and reducers as per Drawing. Use the proper sized "T's" and reducers.
- .3 Extend risers into sub base aggregate and or make connections to drain lines where indicated on the Drawings.
- .4 Where inspection risers are indicated to be placed on top of the Silva Cell Deck, assemble riser and fittings to dimensions requires such that the rim of the riser is flush with the paving. Set the rim top with a slope consistent with the slope of the pavement.
- .5 Adjust the location of the riser such that the centre of the riser falls along the centreline of one of the ribbed slots in the deck. Cut the deck geotextile with an X cut and insert the riser through the geotextile.
- .6 Make a geotextile collar secured to the riser with zip ties that over lap the surrounding geotextile a minimum of 12-inches. Secure in place with tape.
- .7 Brace all risers while backfill and paving is being installed to secure its location and elevation.
- .8 Install clean-out caps on top of each riser flush with finish grade of pavement.

3.7 Installation of Irrigation Sleeves

- .1 Where irrigation sleeves are required, coordinate timing and location with other work. Install in accordance with Specification E5 – Micro Irrigation System Requirements.

3.8 Installation of Granular Base (Below Cell Frame)

- .1 Install sub-base to the depths indicated on the Drawings, under the first layer of Silva Cell frames.
- .2 Compact sub base layer to a minimum of 95% standard Proctor Density, in accordance with CW 3110.
- .3 Grade surface in a plane parallel to the grades of the paving above.
- .4 The tolerance for dips and bumps in the aggregate under Silva Cells shall be a 9mm deviation from the plane in 3m and 3mm in 1200mm.
- .5 The grade and elevations of the base under the Silva Cells shall be approved by the Contract Administrator prior to proceeding with the installation of the Silva Cells.

3.9 Mock Up

- .1 Prior to the installation of all Silva Cells, construct a mock up of the complete installation at the site. The installation of the mock up shall be in the presence of the Contract Administrator.
- .2 The mock up shall be a minimum of 100 square feet in area and include the complete Silva Cell system installation on compacted sub-base, drainage installation, base course aggregate and geotextile as required, geogrids, backfill, planting soil with compaction, decks, and top geotextile. Indicate location of trees as part of the mock up.
- .3 The mock up area may remain as part of the installed work at the end of the project provided that it remains in good condition and meets all the conditions of the Specifications.

3.10 Root Barrier

- .1 Install root barrier along roadway edge of tree pit or where required to protect services and other infrastructure in accordance with manufacturer's written instructions. Install with vertical root directing ribs facing inwards towards trees or plants.
- .2 Connect panels together as required with manufacturer's standard joining system.

3.11 Installation of Silva Cells

- .1 Identify the outline layout of the structure and the edges of paving around tree planting areas on the floor of the excavation, using spray paint or chalk line. The layout shall be calculated to include shift in layout locations due to depth and the slope of the Cells.

- .2 Lay out the first layer of Silva Cell frames on the sub-base. Verify that the layout is consistent with the required locations and dimensions of paving edges to be constructed over the Silva Cells.
- .3 Check each Silva Cell frame unit for damage prior to placing on the sub-base. Any cracked or chipped unit shall be rejected.
- .4 Place frames no less than 1 inch (25mm) and no more than 3 inches (75mm) apart.
- .5 Assure that each frame sits solidly on the surface of the sub base. Frames shall not rock or bend over any stone or other obstruction protruding above the surface of the sub base material. Frames shall not bend into dips in the sub base material. Adjust sub base material including larger pieces of aggregate under each frame to provide a solid base of support.
- .6 Anchor each Silva Cell into sub base with four-10 inch (250mm) spikes, driven through the molded holes in the Cell frame base to maintain cell spacing and layout during the installation of planting soil and backfill.
- .7 Install the second layer of Silva Cell frames on top of the first layer. Comply with manufacturer's requirements to correctly register and connect the Cell frames together.
- .8 Register each frame on top of the lower frame post. Rotate each frame registration arrow in the opposite direction from the frame below to assure that connector tabs firmly connect. Each frame shall be solidly seated on the one below.
- .9 Build layers as stacks of frames set one directly over the other. Do not set any frame half on one Cell frame below and half on an adjacent frame.
- .10 Install Strongbacks on top of the Silva Cell frames prior to installing planting soil and backfill. Strongbacks are required only during the installation and compaction of the planting soil and backfill. Strongbacks should be moved as the work progresses across the installation, and prior to the installation of Silva Cell decks.

3.12 Installation of Street Tree Planting Medium and Geogrid

- .1 Install street geogrid curtain, street tree planting medium, and backfill as indicated on the Drawings. The process of installation requires that these three materials be installed and compacted together in several alternating operations to achieve correct compaction relationships within the system.
- .2 Geogrid curtains are required around the outside edge of the Silva Cells between the planting medium and the compacted backfill. Do not place geogrid curtains between the edge of the cells and any planting area adjacent to the Cells.
- .3 Pre-cut the geogrid to allow for 6 inches (150mm) minimum under lapping below backfill, and 12 inches (300mm) minimum overlapping top of Silva Cell stack.
- .4 Where cell layout causes a change direction in the plane of the geogrid, slice the top and bottom flaps of the material so that it lies flat on the top of the cell deck and aggregate base course along both planes.
- .5 Provide a minimum of 300mm (12 inch) overlaps between different sheets of geogrid.

- .6 Place the geogrid in the space between the Silva Cell frames and the sides of the excavation. Attach the geogrid to the Silva Cell frames using 5 x 300mm zip ties. Attach with zip ties at every cell and at Cell Deck.
- .7 Install no more than two layers of Silva Cell frames before beginning to install planting soil and backfill. Compact the planting soil within the Silva Cell frames first followed by the backfill material outside the frames in alternating lifts until the desired elevations and density is achieved in both materials.
- .8 Install and compact backfill material in the space between the Silva Cells and the sides of the excavation in lifts that do not exceed 200mm.
- .9 Compact backfill to 95% of maximum dry density using a powered mechanical compactor. Use a pneumatic compacting tool or narrow foot jumping jack compactor for spaces less than 300mm wide and a 300mm wide jumping jack compactor or larger equipment in wider spaces.
- .10 Maintain the geogrid curtain between the Silva Cells frames and the backfill material.
- .11 Install backfill in alternating lifts with the planting soil inside the Silva Cells placed first.
- .12 Fill the first layer or layers of frames with planting medium, specified in Specification E5 Street Tree Planting Medium. Install in lifts that do not exceed 200mm. Lightly compact the soil to a maximum dry density of 85% inside the frames at each lift to remove air pockets and settle the soil within the frames. If the planting soil becomes overly compacted, remove the soil and reinstall. Use hand tools or other equipment that does not damage the Silva Cell frames.
- .13 **Do not walk on or place compacting equipment directly on horizontal beams of the frames.**
- .14 Work soil under the horizontal frame beams of the second level of Cell frames and between columns eliminating air pockets and voids. Fill each frame such that there is a minimum of 250mm of soil over the top of horizontal frame beams before resuming compaction.
- .15 The top 25-50mm of each frame post should remain exposed above the soil to allow the placement of the next frame or deck.

3.13 Installation of Third Silva Cell Layer

- .1 After the first two layers of Silva Cell frames have been installed, filled with planting medium, backfilled and compacted, proceed to install the third layer of Silva Cells frames where indicated on the Drawings. Comply with manufacturer's requirements to correctly register and connect the Cell frames together. Remove the strongbacks. Sweep any soil from tops before adding the next layer of frames. Install Strongbacks on top of third layer of Silva Cells.
- .2 Continue to install and compact the planting soil within the Silva Cell frames and the backfill material outside the frames in alternating lifts until the desired elevations and density is achieved in both soils.
- .3

3.14 Irrigation

- .1 Where indicated in the Drawings, install irrigation lines and heads in accordance with Specification E5 – Micro Irrigation System Requirements.

3.15 Preparation for Installing Silva Cell Decks

- .1 The planting soil shall be brought to level not more than 1 inch (25mm) below the bottom of the Silva Cell Deck when installed.
- .2 When using mulch, add a final layer of planting soil as required to bring the planting soil level to not more than 3 inches (75 mm) below the bottom of the Silva Cell Deck when installed. When using air space rather than compost, the planting soil shall be brought to level not more than 1 inch (25 mm) below the bottom of the Silva Cell Deck when installed.
- .3 Obtain final approval by the Contract Administrator of soil installation prior to installation of the Silva Cell deck.
- .4 Remove Strongbacks after planting soil and backfill has been compacted to the top of the entire set of Silva Cells.
- .5 Install 3 inches (75 mm) of mulch, or leave 1-inch (25 mm) air space, below Silva Cell Deck as indicated on the Drawings.

3.16 Silva Cell Deck Installation

- .1 Install the Silva Cell Decks over the top of each frame stack. Clean dirt from the tops of the Silva Cell frame columns. Register the deck and make connections as recommended by the manufacturer to secure the deck to the top of the Silva Cell Frame. Secure each deck at the four corners with screw fasteners supplied by the manufacturer. Assure that each deck is seated firmly on the frame top with all connectors attached.
- .2 Install and compact remaining backfill material such that the granular material outside the limits of the Silva Cells is flush with the top of the installed deck.

3.17 Installation of Non-woven Geotextile, Geogrid, and Aggregate Over the Deck

- .1 Overlap geogrid over the top of the Silva Cell Decks, with minimum of 12 inches (300mm) overlap.
- .2 Place non-woven geotextile over the top of the deck where indicated on the Drawings, extending beyond the outside edge of the excavation by at least 18 inches (450mm). Any joints must be overlapped by a minimum of 18 inches (450mm).
- .3 Cut geotextile a minimum of 20 percent larger than the size of the deck area to be covered to accommodate for required conforming of the geotextile and stone to the deck contours.
- .4 Install the granular base course over the geotextile immediately after completing the installation of the fabrics and inspection risers. Work the aggregate from one side of the deck to the other to assure that the fabric and aggregate conforms to the cell deck contours. Do not apply aggregate in several positions at the same time.

- .5 Depth of granular base course above cell decks: minimum 100mm under poured concrete sidewalk, minimum 300mm under unit pavers.
- .6 Place the granular base material using equipment situated outside the limits of the excavated area. Use small, low impact material mover such as a concrete buggy or Bobcat to move aggregate over the cells. Work over material already in place. Never allow any motorized equipment of any size to operate directly on the Silva Cell Deck.
- .7 For large or confined areas, where aggregate cannot easily be placed from the edges of the excavated area, obtain approval for the installation procedure and types of equipment to be used in the installation from the Silva Cell manufacturer.
- .8 Compact aggregate base course, in lifts not to exceed 150mm in depth, to 95% of maximum dry density. Utilize a roller or plate compactor with a maximum weight of 450 kg. Make sufficient passes with the compacting equipment and add water as required to attain the required compaction.
- .9 Notify Contract Administrator when aggregate base has been compacted to allow for testing. Obtain approval prior to proceeding with paving.

3.18 Installation of Paving and Thickened Tree Well Edge

- .1 Place paving material over Silva Cell system in accordance with applicable City of Winnipeg specifications.
- .2 Take care when placing paving or other backfill on top of Silva Cell system not to damage the system components.
- .3 Thicken edge of paving at tree well as indicated on the Drawings. Size of tree well as specified.

3.19 Installation of Planting Medium and Mulch within the Tree Planting Area

- .1 Prior to planting trees, install additional planting medium, to the depths indicated, within the tree opening adjacent to paving supported by Silva Cells.
- .2 Remove all rubble, debris, dust and silt from the top of the planting medium that may have accumulated after the initial installation within the Silva Cells.
- .3 Assure that the planting medium under the tree root ball is compacted to approximately 85-90% to prevent settlement of the root ball.
- .4 The planting soil within the tree opening shall be the same soil as in the adjacent Silva Cells.
- .5 Cover the planting soil finished grade with specified mulch to depth indicated on the Drawings.

3.20 Tree Planting

- .1 Plant tree in accordance with Specification E7.
- .2 Backfill street tree planting medium between rootball and cells, compacting sufficiently to provide good soil consistency for tree planting and to minimize

settlement. Fill all gaps between the planting medium in the cells and that in the tree well.

- .3 Install mulch to depth indicated on the Drawings.

3.21 Repair of Cut Geotextile

- .1 In the event that any geotextile over subgrades or the Silva Cell decks must be cut during or after installation, repair the seam with a second piece of geotextile that overlaps the edges of the cut by a minimum of 12-inches in all directions prior to adding aggregate material.

3.22 Tree Grate and Tree Guard

- .1 Where indicated on the Drawings, install tree grate and guard in accordance with Specification E8.

3.23 Protection

- .1 Ensure that all construction traffic and the public are kept away from the limits of the Silva Cells until the final surface materials are in place. No vehicles shall drive directly on the Silva Cell deck or aggregate base course.
- .2 Provide fencing and other barriers to keep vehicles and the public from entering into the area with Silva Cell supported pavement.
- .3 Maintain a minimum of 100mm of aggregate base course on top of the upper geotextile layer during construction.
- .4 When vehicle must cross Silva Cells that does not have final paving surfaces installed, use construction mats designed to distribute vehicle loads to levels that would be expected at the deck surface once final paving has been installed. Use only low impact track vehicles with a maximum surface pressure under the vehicle of 27 kPa (4 pounds per square inch), on top of the mats over Silva Cells prior to the installation of final paving.

3.24 Clean Up

- .1 Perform cleanup during the installation of work and upon completion of the work. Maintain the site free of soil and sediment, free of trash and debris. Remove from site all excess soil materials, debris, and equipment. Repair any damage to adjacent materials and surfaces resulting from installation of this work.

3.25 Quality Control

- .1 Submit Silva Cell manufacturer's letter of review and approval of the project, plans, details and specifications for compliance with product installation requirements prior to commencing Work.
- .2 Determine the Standard Proctor Density for the sub-grade, sub-base and base course materials at the optimum moisture content in accordance with ASTM Standard D698. The field density of each sub-grade, sub-base and base course layer will be a percentage of the applicable Standard Proctor Density, as specified herein.

- .3 Utilize quality control tests to determine the acceptability of the sub-grade, sub-base and base course layers, as placed and compacted before the succeeding layer may be applied.
- .4 Verify the field density of the compacted layers by Field Density Tests in accordance with ASTM Standard D1556, Test for Density of Soil in Place by the Sand-Cone Method, or ASTM Standard D2922, Test of Density of Soil and Soil-Aggregate in Place by Nuclear Methods (Shallow Depth).
- .5 The frequency and number of tests will be as directed by the Contract Administrator.
- .6 Promptly fill holes made by the removal of samples from the layers with appropriate material and thoroughly compact so as to conform in every way with the adjoining material.

4. MEASUREMENT AND PAYMENT

4.1 Supply and Installation

1. Supply and installation of Silva Cells will be measured on a unit basis and paid for at the Contract Unit Price per assembly for the Items of Work listed here below. The quantity to be paid for will be the total number of Silva Cell assemblies supplied and installed in accordance with this specification, accepted and measured by the Contract Administrator.

Items of Work:

- (i) [Supply and Installation of Double Height Silva Cell Assembly]
 - (ii) [Supply and Installation of Triple Height Silva Cell Assembly]
 - (iii) [Supply and Installation of Inspection Riser]
(etc. to be determined by consultant)
2. Assembly includes [base course, topsoil in cells, geotextile, geogrid...] *to be completed by consultant*
 3. Assembly does not include [planting, planting backfill, subdrain...] *to be completed by consultant*

END OF SECTION

E2. RAISED TREE PLANTERS

1. DESCRIPTION

1.1 General

- .1 This Specification shall cover the installation of raised cast-in-place concrete tree planters, including excavation, planter sub drainage, concrete forming, installation and finishing, planter insulation, geotextile, planting medium and mulch.

1.2 Referenced Standard & Draft Construction Specifications

- .1 CW 1120 – Existing Services, Utilities and Structures
- .2 CW 3110 – Sub-grade, Sub-base and Base Course Construction
- .3 CW 3120 – Installation of Sub Drains
- .4 CW 3130 – Supply and Installation of Geotextile Fabrics
- .5 CW 3170 – Earthwork and Grading
- .6 CW 3310 – Portland Cement Concrete Pavement Works
- .7 E5 – Micro Irrigation System Requirements
- .8 E6 – Street Tree Planting Medium
- .9 E7 – Tree Planting – Downtown and Regional Streets
- .10 E8 – Tree Grates and Guards

1.3 Referenced Details

- .1 F2 – Tree Planting in Raised Concrete Planter
- .2 F5 – Tree Planting – Downtown and Regional Streets

2. MATERIALS

2.1 Granular Drainage Course

- .1 Granular drainage material in accordance with Specification CW 3120 - Installation of Sub Drains.

2.2 Sub Drain

- .1 To Specification CW 3120 - Installation of Sub Drains.

2.3 Insulation

- .1 Insulation to be rigid Styrofoam SM 50mm thick or approved equal.

2.4 Geotextile and Filter Cloth

- .1 Geotextile in accordance with Specification CW3120.
- .2 Filter cloth to be UV stable, black, woven cloth.

2.5 Concrete Materials and Accessories

- .1 Concrete materials and accessories in accordance with Specification CW 3310 – Portland Cement Concrete Pavement Works, to suit loads designed by engineer.

2.6 Street Tree Planting Medium

- .1 Refer to Specification E6: Street Tree Planting Medium.

2.7 Mulch

- .1 Refer to Specification E7: Tree Planting – Downtown and Regional Streets.
- .2 Or approved alternate.

2.8 Submittals

- .1 Prior to installation, submit to the Contract Administrator samples of the following materials:
 - (a) Geotextile: 1 sq.m
 - (b) Filter cloth: 1 sq.m
 - (c) Mulch: 500 g

3. CONSTRUCTION METHODS

- .1 The Contractor must ensure that all buried utilities and services are located and if necessary, protected and exposed prior to any excavation in accordance with Specification CW 1120.
- .2 Excavate the tree pits by hand to the dimensions and depth shown on the Drawings. Soft dig/ day lighting process to be used in area of existing underground utilities. Ensure base of tree pit slopes to drain to roadway drainage system (min 2% slope).
- .3 If pavement has been constructed, roadway base and sub-base extending more than 450mm from the edge of roadway pavement may be removed where required to achieve tree pit width as specified on Drawings.
- .4 Clear excavation of all construction debris, trash, rubble and any foreign material. Excavate and remove oil spills and other soil contamination sufficiently to remove the harmful material. Fill over excavations with approved fill and compact to the required subgrade compaction.
- .5 All excavated material shall be disposed of off site as per CW 1130.
- .6 Backfill between roadway base gravel and tree pit edge with compacted granular where required.

- .7 If roadway has no sub drain, supply and place 150 mm depth granite drainage course with perforated pipe in accordance with Specification CW 3120 – Installation of Sub Drains and as shown on the Drawings. Ensure pipe has minimum 25mm cover of drainage course above and below.
- .8 Coordinate installation of all irrigation sleeves, lines, heads and equipment with irrigation contractor. Make provisions and ensure proper timing of operations.
- .9 Construct cast-in-place concrete planter in accordance with Specification CW 3310 – Portland Cement Concrete Pavement Works and the Drawings.
- .10 Install rigid insulation around inside perimeter of planter.
- .11 Cover drainage course and sides of tree pit with geotextile.
- .12 Clear all construction related debris from planter prior to placing planting medium
- .13 Backfill with planting medium compacting sufficiently to provide good soil consistency for tree planting and to minimize settlement.
- .14 Plant trees in locations shown on the Drawings in accordance with Specification E7: Tree Planting – Downtown and Regional Streets.
- .15 Install filter cloth over entire planter area. Anchor cloth at 300mm O.C. Ensure sections of filter cloth are overlapped minimum 300mm with anchoring on both edges. No filter cloth is required where annuals/perennials are planted at the base of the trees.
- .16 Cover filter cloth with maximum 100mm depth mulch. Ensure entire area of filter cloth is covered with mulch and depth is sufficient to ensure shifting does not expose cloth. Do not fill mulch past level of planter lip.

4. MEASUREMENT AND PAYMENT

- .1 Supply and installation of Raised Tree Planters will be measured on a unit basis and paid for at the Contract Unit Price per assembly for the Items of Work listed here below. The quantity to be paid for will be the total number of Raised Tree Planter assemblies supplied and installed in accordance with this specification, accepted and measured by the Contract Administrator.

Items of Work:

- (iv) [Supply and Installation of Raised Tree Planter]
(etc. to be determined by consultant)
2. Assembly includes [base course, insulation, concrete, geotextile...] *to be completed by consultant*
3. Assembly does not include [planting, planting backfill, subdrain...] *to be completed by consultant*

END OF SECTION

E3. TREE VAULTS

1. DESCRIPTION

1.1 General

- .1 This Specification covers the installation of cast-in-place concrete tree vaults with precast concrete tree covers, sidewalk panels and related excavation, tree vault sub drainage, geotextile, planting medium and mulch.

1.2 Referenced Standard & Draft Construction Specifications

- .1 CW 1120 – Existing Services, Utilities and Structures
- .2 CW 3110 – Sub-grade, Sub-base and Base Course Construction
- .3 CW 3120 – Installation of Sub Drains
- .4 CW 3130 – Supply and Installation of Geotextile Fabrics
- .5 CW 3170 – Earthwork and Grading
- .6 E5 – Micro Irrigation System Requirements
- .7 E6 – Street Tree Planting Medium
- .8 E7 – Tree Planting – Downtown and Regional Streets
- .9 E8 – Tree Grates and Guards

1.3 Referenced Details

- .1 F3 – Tree Planting in Tree Vault
- .2 F5 – Tree Planting – Downtown and Regional Streets
- .3 F6 – Standard Tree Guard

2. MATERIALS

2.1 Granular Drainage Course

- .1 Granular drainage material in accordance with Specification CW 3120 - Installation of Sub Drains.

2.2 Sub Drain

- .1 To Specification CW 3120 - Installation of Sub Drains.

2.3 Geotextile

- .1 Geotextile in accordance with CW 3120.

2.4 Root Barrier

- .1 DeepRoot UB 18, 450mm x600mm panels or approved equal.

2.5 Concrete Materials and Accessories

- .1 Concrete materials and accessories in accordance with Specification CW 3310 – Portland Cement Concrete Pavement Works, to suit loads designed by engineer.

2.6 Precast Concrete Vault Covers

- .1 Tree cover to be two-piece precast concrete tree cover with 500mm diameter opening in centre.
- .2 Sidewalk panel to be min. 150mm thick reinforced precast concrete panel to accommodate AASHTO HS-20 loading. Manufacturer to supply shop drawings stamped by a structural engineer.
- .3 Precast concrete tree covers and sidewalk panels supplied by Barkman Concrete Ltd., 909 Gateway Road, Winnipeg, MB , Phone: 667-3310, or approved equal.

2.7 Planting Medium

- .1 In accordance with Specification E6: Street Tree Planting Medium.

2.8 Submittals

- .1 Prior to installation, submit to the Contract Administrator samples of the following materials:
 - (a) Geotextile: 1 sq.m
 - (b) Root barrier: 1 panel
- .2 Prior to installation, arrange for inspection and approval of the following materials:
 - (a) Tree cover: 1 panel
 - (b) Sidewalk panel: 1 panel

3. CONSTRUCTION METHODS

- .1 The Contractor must ensure that all buried utilities and services are located and if necessary, protected and exposed prior to any excavation in accordance with Specification CW 1120.
- .2 Excavate the tree vault to the dimensions and depth shown on the Drawings. Soft dig/ day lighting process to be used in area of existing underground utilities. Ensure base of tree pit slopes to drain toward roadway drainage system (min 2% slope).
- .3 Remove sidewalk base and sub base where required to achieve tree pit width indicated on the Drawings. Do not remove any base or sub-base material within 450mm of back of curb.
- .4 Clear excavation of all construction debris, trash, rubble and any foreign material. Excavate and remove oil spills and other soil contamination sufficiently to remove

the harmful material. Fill over excavations with approved fill and compact to the required subgrade compaction.

- .5 All excavated material shall be disposed of off site as per CW 1130.
- .6 Backfill between roadway base gravel and tree vault edge with compacted granular where required.
- .7 If roadway has no sub drain, supply and place 150 mm depth granite drainage course with perforated pipe in accordance with Specification CW 3120 – Installation of Sub Drains and as shown on the Drawings. Ensure pipe has minimum 25mm cover of drainage course above and below.
- .8 Coordinate installation of all irrigation sleeves, lines, heads and equipment with irrigation contractor. Make provisions and ensure proper timing of operations.
- .9 Construct cast-in-place concrete tree vault in accordance with Specification CW 3310 – Portland Cement Concrete Pavement Works and the Drawings.
- .10 Install root barrier along roadway edge of tree pit where shown on Drawing and as directed by the Contract Administrator.
- .11 Cover drainage course and sides of tree pit with geotextile in accordance with Specification CW 3120 – Installation of Sub Drains and as shown on the Drawings.
- .12 Remove and dispose of all construction related debris from tree vault prior to placing planting medium.
- .13 Backfill with street tree planting medium compacting sufficiently to provide good soil consistency for tree planting and to minimize settlement.
- .14 Plant trees in locations as per the Drawings, in accordance with Specification E7: Tree Planting – Downtown and Regional Streets. Ensure tree trunk is centred on opening of tree covers.
- .15 After tree planting, ensure that the finished soil level is 100 mm below bottom edge of tree cover and 25mm below bottom edge of sidewalk panel.
- .16 Install sidewalk panels and tree covers ensuring edges are supported by tree well.
- .17 Where indicated on the Drawings, install tree guard in accordance with Specification E8.

4. MEASUREMENT AND PAYMENT

1. Supply and installation of Tree Vaults will be measured on a unit basis and paid for at the Contract Unit Price for the Items of Work listed below. The quantity to be paid for will be the total number of Tree Vault assemblies supplied and installed in accordance with this specification, accepted and measured by the Contract Administrator.

Items of Work:

- (i) [Supply and Installation of 30m³ Tree Vault]
- (ii) [Supply and Installation of 60m³ Tree Vault]

(etc. to be determined by consultant)

2. Assembly includes [base course, insulation, geotextile...] *to be completed by consultant*
3. Assembly does not include [planting, planting backfill, subdrain...] *to be completed by consultant.*

END OF SECTION

E4. STRUCTURAL SOIL

1. DESCRIPTION

1.1 General

- .1 This Specification covers the mixing and installation of 'structural soil' for tree planting in hard surfaced areas in the downtown and along regional streets. Structural soil is a blend of soil and granular material that serves as a growing medium for tree roots and a base course for pavement.

1.2 Referenced Standard & Draft Construction Specifications

- .1 CW 1120 – Existing Services, Utilities and Structures
- .2 CW 3110 – Sub-grade, Sub-base and Base Course Construction
- .3 CW 3120 – Installation of Sub Drains
- .4 CW 3130 – Supply and Installation of Geotextile Fabrics
- .5 CW 3170 – Earthwork and Grading
- .6 CW 3325 – Portland Cement Concrete Sidewalk
- .7 CW 3330 – Installation of Interlocking Pavement Stones
- .8 E5 – Micro Irrigation System Requirements
- .9 E6 – Street Tree Planting Medium
- .10 E7 – Tree Planting – Downtown and Regional Streets
- .11 E8 – Tree Grates and Guards.

1.3 Referenced Details

- .1 F4 – Tree Planting Using Structural Soil
- .2 F5 – Tree Planting – Downtown and Regional Streets
- .3 F6 – Standard Tree Guard

2. MATERIALS

2.1 Clay Loam

- .1 Soil component shall be "Clay Loam" based on the USDA classification system as determined by mechanical analysis (ASTM D-422). Uniform composition, without admixture of subsoil, free of stones greater than 12 mm, lumps, plants and their roots, debris and other extraneous matter over one 25 mm in diameter or excess of smaller pieces of the same materials as determined by the Contract Administrator. Free from toxic substances harmful to plant growth. Obtained from naturally well-

drained areas, never stripped of topsoil with a history of satisfactory vegetative growth. Clay Loam shall contain not less than 2% nor more than 5% organic matter as determined by the loss on ignition of oven-dried samples. Test samples shall be oven-dried to a constant weight at a temperature of 110 degrees C., plus or minus 9 degrees.

.2 Mechanical Analysis

Textural Class	% of total weight
Gravel	less than 5%
Sand	20 - 45%
Silt	20 - 50%
Clay	20 - 40%

.3 Chemical Analysis

- (a) pH between 5.5 to 6.5
- (b) Percent organic matter 2 -5% by dry weight.
- (c) Nutrient levels as required by the testing laboratory recommendations for the type of plants to be grown in the soil.
- (d) Toxic elements and compounds below the United States Environmental Protection Agency Standards for Exceptional Quality sludge or local standard; whichever is more stringent.
- (e) Soluble salt less than 1.0 Millimho per cm.
- (f) Cation Exchange Capacity (CEC) greater than 10
- (g) Carbon/Nitrogen Ratio less than 33:1.

2.2 Granular Material

- .1 Granular material will consist of natural gravel, crushed stone or other materials of similar characteristics having clean, hard, strong, durable, uncoated particles free from injurious amounts of soft, friable, thin, elongated or laminated pieces, alkali, organic or other deleterious matter. Quarried limestone and dolomite are not acceptable. Grading requirements to meet those specified for Drainage Material under Specification CW 3120 – Installation of Subdrains.

2.3 Hydrogel

- .1 Hydrogel shall be a potassium propenoate-propenamide copolymer Hydrogel as manufactured by Gelscape by Amereq Corporation. (800) 832-8788, or approved equal.

2.4 Water

- .1 The Contractor shall be responsible to furnish his own supply of water to the site at no extra cost. All work injured or damaged due to the lack of water, or the use of too much water, shall be the Contractor's responsibility to correct. Water shall be free from impurities injurious to vegetation.

2.5 Structural Soil

- .1 A uniformly blended mixture of approved granular material, Clay Loam and Hydrogel, mixed approximately to the following proportion:

<u>MATERIAL</u>	<u>UNIT OF WEIGHT (either metric or English)</u>
Granular Material	100
Clay Loam (dry)	(Approx. 20) determined by the test of the mix
Hydrogel	0.03

The initial mix design for testing shall be determined by adjusting the ratio between the Granular Material and the Clay Loam. Adjust final mix dry weight mixing proportion to decrease soil in mixture if CBR test results fail to meet acceptance (CBR #50).

2.6 Geotextile

- .1 Geotextile in accordance with Specification CW 3130.

3. CONSTRUCTION METHOD

3.1 Mix Design

- .1 At least 30 days prior to ordering materials for structural soil, the Contractor shall submit to the Contract Administrator samples specified below. No materials shall be ordered until the required samples have been reviewed and approved by the Contract Administrator.
- (a) Clay Loam: Submit two (2) – 500 millilitre representative samples of clay loam, labelled with source and date.
 - (b) Granular Material: Submit two (2) - 1000 millilitre representative samples of granular material, labelled with source and date.
 - (c) Structural Soil: Submit one (1) – 1000 millilitre representative sample of assembled Structural Soil, labelled with date.
- .2 All material supplied under this Specification shall be subject to inspection and testing by a Testing Laboratory designated by the City of Winnipeg or the Contract Administrator.
- .3 Based on samples and the analysis of the mix components, the Contract Administrator and the Contractor will jointly determine if adjustments are required to the approximate mix ratio specified above. The mix will be tested and further adjusted as necessary until the requirements of this Specification are met.

3.2 Delivery, Storage and Handling

- .1 Do not deliver or place soils in frozen, wet, or muddy conditions.
- .2 Protect soils and mixes from absorbing excess water and from erosion at all times. Do not store materials unprotected from large rainfall events. Do not allow excess water to enter site prior to compaction. If water is introduced into the material after grading, allow material to drain or aerate to optimum compaction moisture content.

3.3 Soil Mixing and Quality Control Testing

- .1 All Structural Soil mixing shall be performed at a suitable yard using appropriate soil measuring, mixing and shredding equipment of sufficient capacity and capability to assure proper quality control and consistent mix ratios. No mixing of Structural Soil at the project site shall be permitted.
- .2 Calculate volume of structural soil required and confirm with Contract Administrator prior to mixing. The Contractor shall mix sufficient material in advance of the time needed at the job site to allow adequate time for final quality control testing as required by the progress of the work.
- .3 Maintain adequate moisture content during the mixing process. Soils and mix components shall easily shred and break down without clumping. Soil clods shall easily break down into a fine crumbly texture. Soils shall not be overly wet or dry. The Contractor shall measure and monitor the amount of soil moisture at the mixing site periodically during the mixing process.
- .4 Mixing procedure for front-end loader shall be as follows:
 - (a) On a flat asphalt or concrete paved surface, spread an 8 inch to 12 inch layer of granular material.
 - (b) Spread evenly over the stone the specified amount of dry hydrogel.
 - (c) Spread over the dry hydrogel and granular material a proportional amount of clay loam according to the mix design.
 - (d) Blend the entire amount by turning, using a front-end loader or other suitable equipment until a consistent blend is produced.
 - (e) Add moisture gradually and evenly during the blending and turning operation as required to achieve the required moisture content. Delay applications of moisture for 10 minutes prior to successive applications. Once established, mixing should produce a material within 1% of the optimum moisture level for compaction.
- .5 Pugging operation mixing procedure may be as follows:
 - (a) Feed a known weight of granular material into the mixing trough.
 - (b) Add hydrogel as a slurry into trough and mix slurry and stone into a uniform blend.
 - (c) Meter in soil in proper proportion of Clay loam Soil While stone-slurry mixture is in motion.
 - (d) Add water to bring mixture to target moisture content after factoring in water from the slurry and the Clay-loam moisture.
 - (e) Auger out to stockpile or transport vehicle (or into pit if using a portable pugging operation).
- .6 Storage piles shall be protected from rain and erosion by covering with plastic sheeting.

3.4 Soil Amendments

- .1 Add soil amendments to alter soil fertility including fertilizers and pH adjustment at the time of mixing at the rates recommended by the soil test.
- .2 Soil pH shall be adjusted to fall within a value of 5.5 and 6.5.
- .3 Soil component carbon/nitrogen ratio shall be adjusted to be less than 33:1.

3.5 Underground Utilities and Subsurface Conditions

- .1 The Contractor must ensure that all buried utilities and services are located and if necessary, protected and exposed prior to any excavation in accordance with Specification CW 1120.

3.6 Site Preparation

- .1 Do not proceed with the installation of the Structural Soil material until all walls, curb footings and utility work in the area have been installed and approved. For site elements dependent on Structural Soil for foundation support, postpone installation until immediately after the installation of Structural Soil.
- .2 Install subsurface drain lines where shown on the Drawings prior to installation of Structural Soil material, in accordance with Specification CW 3120 – Installation of Sub Drains.
- .3 Excavate and compact the proposed subgrade to depths, slopes and widths as shown on the Drawings. Maintain all required angles of repose of the adjacent materials as shown on the drawings. Do not over excavate compacted subgrades of adjacent pavement or structures.
- .4 Confirm that the subgrade is at the proper elevation and compacted as required under Specification CW 3110 – Sub-grade, Sub-base and Base Course Construction. Sub-grade elevations shall slope parallel to the finished grade and or toward the subsurface drain lines as shown on the Drawings.
- .5 Clear the excavation of all construction debris, trash, rubble and any foreign material. Excavate and remove oil spills and other soil contamination sufficiently to remove the harmful material. Fill over excavations with approved fill and compact to the required subgrade compaction.

3.7 Geotextile

- .1 If sub-grade compaction target cannot be achieved, line compacted sub-grade and sides of structural soil trench with woven geotextile in accordance with Specification CW 3130, as instructed by Contract Administrator's prior to installing structural soils.

3.8 Installation of Structural Soil Material

- .1 Install Structural Soil in 150mm lifts and compact each lift. All structural soil trench depths to be a minimum of 900mm deep from top of structural soil profile to bottom of structural soil profile, as per Drawings.
- .2 Compact all materials to a minimum of 95% Standard Proctor Density.

- .3 Bring Structural Soils to finished grades as shown on the Drawings. Immediately protect the Structural Soil material from contamination by toxic materials, trash, debris, water containing cement, clay, silt or materials that will alter the particle size distribution of the mix with plastic or plywood as directed by the Contract Administrator. Remove and replace any contaminated material as directed by the Contract Administrator.
- .4 The Contract Administrator may periodically check the material being delivered and installed at the site for colour and texture consistency with the approved sample. In the event that the installed material varies significantly from the approved sample, the Contract Administrator may request that the Contactor test the installed Structural Soil. Any soil that varies significantly from the approved testing results, as determined by the Contract Administrator, shall be removed and new Structural Soil installed that meets these Specifications.

3.9 Finish Grading

- .1 Adjust finish grades to meet field conditions as directed.
 - (a) Provide smooth transitions between slopes of different gradients and direction.
 - (b) Fill all dips with structural soil and remove any bumps in the overall plane of the slope.
 - (c) The tolerance for dips and bumps in Structural Soil areas shall be a 25mm deviation from the plane in 3 metres.
- .2 All fine grading shall be inspected and approved by the Contract Administrator prior to the installation of other items to be placed on the Structural Soil.

3.10 Acceptance of Structural Soil

- .1 The Contract Administrator will inspect the work upon the request of the Contractor. Request for inspection shall be received by the Contract Administrator at least 2 days before the anticipated date of inspection. Contract Administrator will issue a report to the Contractor and City advising if the structural soil is accepted or has deficiencies to be addressed.

3.11 Installation of Paving

- .1 Place paving material over structural soil immediately after approval is received, in accordance with the Drawings and applicable City of Winnipeg specifications.

3.12 Installation of Planting Medium in Tree Well

- .1 Remove all rubble, debris, dust and silt from the tree well that may have accumulated during the installation of structural soils.
- .2 Install planting medium in accordance with Specification E6: Street Tree Planting Medium.

3.13 Tree Planting

- .1 Plant tree in accordance with Specification E7: Tree Planting – Downtown and Regional Streets

- .2 Backfill street tree planting medium between rootball and cells, compacting sufficiently to provide good soil consistency for tree planting and to minimize settlement. Fill all gaps between the planting medium in the cells and that in the tree well.
- .3 Install mulch to depth indicated on the Drawings.

3.14 Tree Grate and Tree Guard

- .1 Where indicated on the Drawings, install tree grate and guard in accordance with Specification E8: Tree Grates and Guards.

3.15 Clean-Up

- .1 Upon completion of the Structural Soil installation operations, clean areas within the contract limits. Remove all excess fills, soils and mix stockpiles and legally dispose of all waste materials, trash and debris. Remove all tools and equipment and provide a clean, clear site. Sweep, do not wash, all paving and other exposed surfaces of dirt and mud until the paving has been installed over the Structural Soil material. Do no washing until finished materials covering Structural Soil material are in place.

4. MEASUREMENT AND PAYMENT

- .1 The supply and installation of Structural Soil will be measured on a volume basis and paid for at the Contract Unit Price per cubic metre. The volume to be paid for shall be the number of cubic metres manufactured and installed in accordance with this Specification and accepted by the Contract Administrator, as computed from measurements made by the Contract Administrator.
- .2 Contract Unit Price includes [geotextile...] *to be completed by consultant*
- .3 Contract Unit Price does not include [planting, planting backfill, subdrain...] *to be completed by consultant.*

END OF SECTION

E5. MICRO IRRIGATION SYSTEM REQUIREMENTS

1. DESCRIPTION

1.1 General

- .1 This Specification shall cover the requirements for the supply, installation and maintenance of a micro-irrigation system for boulevard and median tree planting on downtown and regional streets. It is supplementary to Specification CW 3530 – Manual Irrigation System.

1.2 Referenced Standard & Draft Construction Specifications

- .1 CW 1120 – Existing Services, Utilities and Structures
- .2 CW 3530 – Manual Irrigation System
- .3 E6 – Street Tree Planting Medium
- .4 E7 – Tree Planting – Downtown and Regional Streets
- .5 E8 – Tree Grates and Guards.

1.3 Related Details

- .1 SD-241A – Typical Dual Check Backflow Preventer and Meter in C.S.P. Enclosure
- .2 SD-241B – Typical Double Check Valve Assembly and Meter in C.S.P. Enclosure
- .3 F1– Tree Planting using Silva Cells
- .4 F2 – Tree Planting in Raised Concrete Planter
- .5 F3 – Tree Planting in Tree Vault
- .6 F5 – Tree Planting – Downtown and Regional Streets

2. MATERIALS

2.1 HDPE pipe

- .1 Pipe shall conform to the requirements of CW 3530.

2.2 Fittings for HDPE pipe

- .1 Approved saddle fittings at head connections. Socket fusion fittings at pipe connections. Fittings to be approved by pipe manufacturer for fusion with pipe.

2.3 Risers

- .1 Galvanized steel pipe and fittings or approved alternate.

2.4 Sleeves

- .1 Series 160 PVC pipe of sufficient diameter to allow clear passage of irrigation pipe and control wires.

2.5 Manual Isolation Valves

- .1 In accordance with Specification CW 3530. Sizes as indicated on the Drawings or as required to suit application.

2.6 Battery operated automatic zone control valves

- .1 150 psi rated, normally closed, 24 VAC electric solenoid valve with manual operation capability and flow control adjustment. Glass reinforced nylon body and bonnet or other approved durable material. Valve serviceable from top without removal from line. Control module to operate on 9 volt battery and provide scheduling features suitable for the intended installation.

2.7 Valve and Meter boxes

- .1 High density polyethylene or fibreglass reinforced prefabricated plastic boxes complete with locking cover and stainless steel bolt. Size to suit valve clusters and meters as indicated.

2.8 Sprinklers

- .1 Flood bubbler: bodies constructed of heavy duty ABS plastic. Pressure compensating low flow system.
- .2 Submit flow calculations and nozzle sizes with Shop Drawings for approval by Contract Administrator.
- .3 Provide check valves to risers of all sprinklers not equipped with an internal check valve.

2.9 Backflow Prevention

- .1 To Specification CW 3530.

3. CONSTRUCTION METHODS

3.1 System Requirements

- .1 Performance Criteria
 - (a) Design automatic tree watering system to provide 30 gallons of actual precipitation per week per tree within a 5 hour per day watering window. Provide one third of the water at an interval of three times per week.
 - (b) System to provide complete wetting of the entire root area.
 - (c) Over-spray on hard surface areas beyond the tree pit is not acceptable.
 - (d) Provide system for winterization.

3.2 System Design, Layout and Inspection

- .1 Provide detailed layout plan showing zoning, pipe layout and valve locations for approval by Contract Administrator.
- .2 All work shall be laid out by the Contractor in conformance to the layout shown on their approved plan. The Contractor shall be fully responsible for the accuracy thereof.
- .3 Mark locations of heads and valves and receive approval from the Contract Administrator prior to excavation and installation. Use stakes or other approved non-permanent marking method.
- .4 Install main lines and laterals and receive approval from Contract Administrator prior to backfilling.
- .5 Upon completion of the installation, the entire system shall be tested and balanced. The Contractor shall notify the Contract Administrator for a final test to allow the Contract Administrator to be on site to consult. All components shall then be checked for proper operation and the system shall not be accepted by the Contract Administrator until all portions are operating as intended and all deficiencies have been corrected. Contractor shall provide all pumps, gauges and fittings required for testing.
- .6 Notify Contract Administrator a minimum of 24 hours prior to testing inspection. Do not proceed to subsequent work without the approval of Contract Administrator.

3.3 Protection

- .1 Prevent damage to fencing, trees, landscaping, natural features, benchmarks, existing buildings, existing pavement, surface or underground utility lines which are to remain. Make good any damage.
- .2 The Contractor must ensure that all buried utilities and services are located and if necessary, protected and exposed prior to any excavation in accordance with Specification CW 1120.

3.4 Coordination

- .1 Coordinate work with other contractors who may be working concurrently on site.

3.5 Water Source

- .1 Connect to supply as indicated on the Drawings, in accordance with Specification CW 2210. Provide complete hydraulic calculations indicating flow and pressure loss at representative zones around the site.

3.6 Meter Enclosure

- .1 Construct meter enclosure, complete with gravel sump, meter, backflow protection, quick couple and all other appurtenances in accordance with Specification CW 3530 and Standard Details SD-241A or SD-241B.
- .2 Use di-electric fittings at connection of galvanized pipe or fittings to copper irrigation mains as required.

3.7 Installation of Pipe

- .1 Install pipe in accordance with Specification CW 3530.
- .2 Use lateral boring to install sleeves under major roads and sidewalks.

3.8 Polyethylene Waterline:

- .1 Install pipe in accordance with Specification CW 3530.

3.9 Control System

- .1 Locate controllers at location as indicated on the Drawings or as approved by the Contract Administrator.

3.10 Single Valve Controllers:

- .1 Install single valve controllers according to manufacturer's instructions, in valve box set plumb and flush with the finished grade.
- .2 Provide 6" (150 mm) depth of pea gravel sump below the valve.
- .3 Provide isolation valve on pressure side of control valve.

3.11 Bubblers

- .1 Install all bubblers on risers firmly fixed in place to avoid toppling.

3.12 Testing and Adjustment

- .1 Upon completion, test irrigation system for proper operation in accordance with Specification CW 3530.

3.13 Maintenance Data and Demonstration Procedures

- .1 Provide maintenance data for operation and maintenance of irrigation system and equipment.
- .2 The maintenance manual shall include all original manufacturers' warranty certificates, controller operation and programming instructions, servicing and replacement procedures for all sprinklers and valves, and procedures for blowing out the system in the fall and charging the system in the spring.
- .3 Demonstrate procedures for Owner as directed by the Contract Administrator.

3.14 As Built Plan

- .1 Upon completion of the work, submit an as-built plan showing exact location of all components of system.
- .2 Provide a control schedule that balances system hydraulics and watering requirements.

3.15 Maintenance

- .1 Blow-out all irrigation water lines prior to freeze-up and reconnect the irrigation system in the spring of the following year.
- .2 Emergency repairs may be required to protect property or permit operation of the work. The Owners shall notify the Contractor immediately, who shall make all necessary repairs. The cost of such emergency repairs shall be paid by the Contractor. Maintenance not of an emergency nature shall be brought to the attention of the Contractor in writing and he shall take the necessary action to correct the faulty work.
- .3 The Contractor shall provide on-site orientation as directed by the Contract Administrator to familiarize the maintenance personnel with the proper operation of the irrigation system and locations of control equipment.

3.16 Clean Up

- .1 Clean site in accordance with Specification CW 3530.

3.17 Quality Control

- .1 Inspection, access, and warranty requirements shall be in accordance with Specification CW 3530.
- .2 End of warranty inspection will be conducted.

4. MEASUREMENT AND PAYMENT

- .1 The supply and installation of Micro Irrigation System will be paid for at the Contract Unit Price for "Micro Irrigation System", which price shall be payment in full for performing all operations herein described and all other items incidental to the Work included in this Specification.

to be modified by consultant to suit project

END OF SECTION

E6. STREET TREE PLANTING MEDIUM

1. DESCRIPTION

1.1 General

- .1 This Specification covers the supply and placing of planting medium and fertilizer for street tree planting on downtown and regional streets.

1.2 Referenced Standard & Draft Construction Specifications

- .1 CW 3540 – Topsoil and Finish Grading for Establishment of Turf Areas
- .2 E1 – Silva Cells
- .3 E2 – Raised Tree Planters
- .4 E3 – Tree Vaults
- .5 E7 – Tree Planting – Downtown and Regional Streets

1.3 Related Details

- .1 F1– Tree Planting using Silva Cells
- .2 F2 – Tree Planting in Raised Concrete Planter
- .3 F3 – Tree Planting in Tree Vault
- .4 F5 – Tree Planting – Downtown and Regional Streets

2. MATERIALS

2.1 General

- .1 Delivery, storage and testing requirements to Specification CW 3540 – Topsoil and Finish Grading for Establishment of Turf Areas.

2.2 Street Tree Planting Medium

- .1 In accordance with the requirements for topsoil specified under Specification CW 3540 – Topsoil and Finish Grading for Establishment of Turf Areas, except organic matter shall be in the range of 5 to 10%.
- .2 The Contract Administrator reserves the right to reject planting soil not conforming to the requirements of these Specifications.

3. CONSTRUCTION METHODS

3.1 Inspection and Approval of Planter/Planting Pit

- .1 Prior to placing street tree planting medium in Silva Cell tree wells (Specification E1), tree vaults (Specification E2), raised tree planters (Specification E3), or structural soil tree wells (Specification E4), or tree pits (Specification E7) verify the following:
 - (a) all construction debris, broken concrete, and excess granular material has been removed.
 - (b) all geotextiles, root barriers, insulation and drainage are installed in accordance with relevant Drawings and Specifications.
- .2 Prior to placing street tree planting medium in turf areas (Specification E7, figure F5), verify the following:
 - (a) all construction debris, broken concrete, and excess granular material has been removed.
 - (b) excavation depth and extent is as specified.
 - (c) sides of excavation have been scarified.
- .3 Obtain approval from Contract Administrator before proceeding.

3.2 Installing Planting Medium

- .1 Place street tree planting medium in accordance with Specification E7: Tree Planting – Downtown and Regional Streets.

3.3 Acceptance

- .1 Contract Administrator will inspect planting medium in place and determine acceptance of material, depth of planting and finish grading.

3.4 Surplus Material

- .1 Dispose of unused materials off site in accordance with CW 1130.

4. MEASUREMENT AND PAYMENT

- .1 The supply and installation of Street Tree Planting Medium will be measured on a volume basis and paid for at the Contract Unit Price per cubic metre. The volume to be paid for shall be the number of cubic metres supplied and installed in accordance with this Specification and accepted by the Contract Administrator, as computed from measurements made by the Contract Administrator.

OR

- .2 The supply and installation of Street Tree Planting Medium is incidental to the Supply and Installation of [Silva Cells] [Tree Vaults] etc.

to be modified by consultant to suit project

END OF SECTION

E7. TREE PLANTING – DOWNTOWN AND REGIONAL STREETS

1. DESCRIPTION

1.1 General

- .1 This Specification covers the supply and installation of nursery-grown trees within the downtown and along regional streets, in turf or paved locations. It is supplementary to, and should be read in conjunction with, the drawings and specifications contained in Schedule "D" Guidelines for the Planting of Boulevard Trees, 2008 or current version.
- .2 The Contract Administrator shall consult the Urban Forestry Branch on matters that do not conform to, or that are not addressed by, these Specifications.

1.2 Related Details

- .1 F1– Tree Planting using Silva Cells
- .2 F2 – Tree Planting in Raised Concrete Planter
- .3 F3 – Tree Planting in Tree Vault
- .4 F5 – Tree Planting – Downtown and Regional Streets

2. MATERIALS

2.1 Testing

- .1 All materials supplied by the Contractor under these Specifications shall be subject to random inspection and testing by the Contract Administrator.
- .2 The Contract Administrator may reject any material(s) that do not comply with this Specification.
- .3 There shall be no charge to the City for any material samples taken for testing by the Contract Administrator.
- .4 The Contractor shall test in situ soil around tree pit for clay content, permeability, nutrient levels, pH level, E.C. (salinity), etc. using a testing laboratory designated by the Contract Administrator. All tests shall be paid for by the Contractor. Tests are required to confirm width and depth of tree pit, amendments for adjacent in situ soil and/or new planting medium volume requirements and need for alternative drainage system.

2.2 Tree Supply

- .1 The Contractor shall be responsible for the safe handling, pick up and delivery of trees to the planting sites.

2.3 Trees

- .1 Trees shall be of the species and sizes noted in Appendix D: Specifications – Deciduous Trees. Plant material which does not have the minimum calliper or root ball diameter specified in Appendix D will be rejected.
- .2 All nursery stock supplied shall be from a Canadian prairie nursery grown root or seed stock. Quality shall be in accordance with the latest “Guide Specification for Nursery Stock of the Canadian Nursery Trades Association”.
- .3 Any nursery stock dug from native stands, wood lots, orchards or neglected nurseries and which have not received proper cultural maintenance as advocated by the Canadian Nursery Trades Association shall be designated as “collected plants”. The use of “collected plants” will not be permitted unless approved by the Contract Administrator.
- .4 The Contract Administrator reserves the right to inspect the plant material at their original source, and to instruct the supplier on root and branch pruning requirements.
- .5 Nomenclature of specified nursery stock shall conform to the International Code of Nomenclature for Cultivated Plants and shall be in accordance with the approved scientific names given in the latest edition of standardized plant names. The names of varieties not named therein are generally in conformity with the names accepted in the nursery trades.
- .6 Plants larger than specified may be used if approved by the Contract Administrator. The use of such plants shall not increase the Contract price.
- .7 All nursery stock shall be measured when the branches are in their normal position. Height and spread dimensions specified refer to the main body of the plant and not from branch tip.
- .8 Where trees are measured by calliper (cal.), reference is made to the diameter of the trunk measured 150 mm above ground as the tree stands in the nursery.
- .9 All nursery stock shall be well branched, true to type, structurally sound, possess a well developed, undamaged root system and shall be free of disease, insect infestations, rodent damage, sunscald, frost cracks and other abrasion or scar to the bark. All parts of the nursery stock shall be moist and show live, green cambium when cut.
- .10 All trees shall have one only, sturdy, reasonably straight and vertical trunk and a well balanced crown with fully developed leader. All evergreens shall be symmetrically grown and branched from ground level up, and must be balled and burlapped unless noted otherwise on the plant list. At least one plant of each variety supplied shall bear a tag showing both the botanical and common name of the plant.

2.4 Protection of Stock

- .1 All nursery stock shall be well protected from damage and drying out from the time of digging until the time of planting on site. All roots shall be cleanly cut; split roots are not acceptable.

- .2 Nursery stock shall be transplanted with care to prevent damage. Points of contact with equipment shall be padded. All nursery stock, which cannot be planted immediately upon arrival at the site, shall be well protected to prevent drying out and shall be kept moist until commencement of planting.
- .3 All nursery stock is to meet the requirements of this specification regardless as to whether it is supplied by the City or the Contractor.

2.5 Planting Medium

- .1 Delivery, storage, and testing requirements for planting medium shall comply with Specification E6: Street Tree Planting Medium.

2.6 Water

- .1 Water shall be free of oils, acids, alkalis, salts and other substances that may be detrimental to plant growth. Water suitable for human consumption shall be acceptable without testing.
- .2 Water from rivers and streams shall not be used without prior approval of the Contract Administrator.
- .3 Should the Contract Administrator determine that water quality testing is necessary, an approved testing laboratory shall perform the test at the sole expense of the Contractor.
- .4 The Contractor shall provide water, so that
 - (a) All costs to provide water for the watering operation and all associated costs shall be borne by the Contractor. These costs may include hydrant permit and meter rental fees.
 - (b) Further to clause 3.7 of CW 1120-R1, the Contractor shall pay for all costs associated with obtaining water in accordance with the Waterworks By-law. Sewer charges will not be assessed for water obtained from a hydrant.

2.7 Trunk Protection Collars

- .1 Plastic weeping tile, 100 mm diameter x 600 mm long.

2.8 Stakes

- .1 T-rail iron stakes 40 x 40 x 5 x 1540 mm long, primed with 1 brush coat of zinc rich plant paint to CGSB 1-GP-191B, uniform in style and colour, or approved equal.

2.9 Guying Materials

- .1 Non-abrasive hose-covered wire, flexible belting or other approved material.

2.10 Mulch

- .1 Mulch shall be a clean bark or wood chip free of leaves, branches and other extraneous matter, consisting of chips not less than 15 mm nor larger than 75 mm in size and not more than 20 mm thick.
- .2 Or approved alternate.

2.11 Granular Drainage Course and Sub Drain

- .1 Granular drainage material in accordance with Specification CW3120 – Installation of Sub Drains.
- .2 Sub drain to specification CW3120 – Installation of Sub Drains.

3. CONSTRUCTION METHODS

3.1 Qualification

- .1 The Contractor shall ensure only experienced personnel, under the direction of a skilled supervisor, shall execute all of the Work. The supervisor shall be on Site at all times during the Work and shall be authorized to make binding decisions on behalf of the Contractor.

3.2 Public Safety/Traffic Control

- .1 In accordance with the Manual of Temporary Traffic Control, the Contractor (“Agency” in the manual) shall make arrangements with the Traffic Services Section of the City of Winnipeg to place all temporary regulatory signs. The Contractor shall bear all costs associated with the placement of temporary traffic control devices by the Traffic Services Section of the City of Winnipeg in connection with the works undertaken by the Contractor. The requirements shall include the following:
 - (a) The Contractor shall barricade the sidewalk surrounding the Work;
 - (b) The Contractor shall maintain traffic flow and ensure that protection is afforded to the road user and that the Contractor's operations shall in no way interfere with the safe operation of traffic.

3.3 Layout

- .1 Planting locations are to be determined on site by the Contract Administrator or designate.
- .2 The Contractor shall obtain all necessary utility clearances prior to the commencement of planting and in a timely manner so as not to jeopardize the schedule of the complete tree planting operation.
- .3 The Contractor is to comply with the instructions on the utility clearance sheets.
- .4 Where a specified planting Site conflicts with underground utilities, the Contractor may modify the precise location in compliance with the utility clearances and the following Minimum Distance Guidelines:
 - (a) Intersections: 6m
 - (b) Private approaches: 1.5m;
 - (c) Light standards, hydro poles, hydrants, manholes and sewer grates: 3m
- .5 Where a planting Site must be modified by more than 1 metre, the Contractor must receive prior approval from the Contract Administrator or designate.

3.4 Planting Period

- .1 The Contractor shall not plant trees during periods of extreme heat, at the discretion of the Contract Administrator.

3.5 Pre-planting Care of Trees

- .1 The Contractor shall coordinate the shipping of trees and excavation of tree pits to ensure no more than a maximum of a 24 hour time lapse has occurred between the plant material arriving on Site and the installation of that plant material.
- .2 Trees shall be transported with care taken to prevent damage:
 - (a) Protect trees against abrasion, exposure and extreme temperature change during transit;
 - (b) Avoid binding of trees with rope or wire that would damage bark, break branches or destroy natural shape of tree;
 - (c) All points of contact with equipment shall be padded;
 - (d) Balled specimens shall be supported and handled with sufficient care, so that the root balls shall not be broken. Broken root balls or root ball consisting of loose soil will not be accepted and shall be replaced. Broken roots of deciduous stock shall be pruned back prior to planting.
- .3 Trees with broken or damaged trunks or branches are not acceptable. Trees with damaged trunks, however caused, will be rejected. No exceptions shall be made in this respect;
- .4 Keep roots moist and protected from sun and wind. Trees that cannot be planted immediately shall be well protected against damage and drying out; if necessary, trees shall be heeled-in in a shaded area and watered well.

3.6 Tree Pit Excavation – General

- .1 The bottom of all excavations shall be protected against freezing.
- .2 Tree pits shall be left open for a maximum of 24 hours.
- .3 Pits that are left open overnight must be covered with a sheet of plywood and be marked with a minimum of one (1) safety cone. Plywood shall be a minimum thickness of 5/8”.
- .4 If the planting location contains a stump with a diameter less than 15 cm it shall be removed.
- .5 Tree pits shall be excavated to a width and length to provide minimum 15cu.m of a combination of planting median and suitable in situ soil (amended as required based on in situ soil test results 2.1.4).
- .6 Depth of tree pit to be adjusted to allow for installation of alternative drainage system where one is required. Alternative drainage system required if roadway has no sub drain and/or in situ soil test results indicate that in situ soils do not drain at a reasonable rate.

3.7 Tree Pit Excavation – Turf Areas

- .1 Tree pits in turf areas shall be minimum 2 times the diameter of the root ball. Pit depth shall be such that the top of the root ball is even with the existing grade. Scarify edges to the depth of one shovel blade.
- .2 Tree pits excavated using a tree spade shall have one foot depth of soil around the edge of the tree pit turned and sufficiently loosened with a shovel to scarify pit.
- .3 In spatially restricted sites, tree pit diameter on the axis parallel to the street or other hard surface shall be a minimum of 2 times the diameter of the root ball. Pit diameter on the axis perpendicular to the street or other hard surface shall be minimum 600 mm (24") greater than the root ball diameter.

3.8 Tree Pit Excavation – Paved Areas

- .1 Tree pits in paved areas shall be sized to suit the selected planting method. Refer to the Drawings and Specifications E1 for Silva Cells, Specification E2 for Raised Tree Planters, Specification E3 for Tree Vaults, and E4 for Structural Soils.

3.9 Planting

- .1 Set trees plumb in the centre of the tree pit. Ensure location of tree will fit opening in tree grate or cover.
- .2 Trees shall be placed on planting medium compacted to approximately 85% Standard Proctor Density or undisturbed soil, to a depth equal to that at which they were originally growing at the nursery.
- .3 Once the tree has been set in its final position, burlap on the root ball shall be cut from the top 1/3 of the root ball.
- .4 If a wire basket has been used, it shall be cut off from the top 1/3 of the root ball.
- .5 Remove twine from the root ball.
- .6 Fill tree pit with planting medium, in layers of 150 mm depth. Compact the independent layers of soil by tamping.
- .7 Tamp soil around root system to eliminate air voids.
- .8 Grade the area around the tree according to the drainage type.
- .9 Form a water dish from the soil around the outside edge of the root ball with a berm 100 mm in height:
- .10 Soil shall not be piled around the tree trunk.
- .11 Planting areas in turf shall be levelled, raked and edged to give a neat appearance.

3.10 Mulch

- .1 Install mulch to 75mm depth or as indicated on the Drawings

- .2 In a turf median, where the width between splash strips does not allow minimum 600mm sod between edge of mulched water dish and splash strip, mulch to extend full width between splash strips.

3.11 Staking

- .1 Stake only where it is deemed necessary by Contract Administrator (e.g. windblown tree).
- .2 Avoid damaging root ball with stake.
- .3 Where hose-covered wire is used, ensure ends are twisted tight. Protruding wire ends are not acceptable.

3.12 Watering

- .1 Water trees immediately upon being planted and every week for the first three (3) weeks after planting.
- .2 Water slowly to ensure water does not run away from the root zone and top 300 mm of the soil around the root system of the tree are well saturated;
- .3 Use a low-pressure open flow nozzle and hose. The water stream must not gouge out a hole in the soil or mulch.
- .4 Secure all necessary utility clearances prior to watering with a deep root feeder.

3.13 Trunk Protection Collars

- .1 Where tree guards are not specified, install trunk protection collars.
- .2 Slice the trunk protection collar pipe vertically and wrap around the base of each tree trunk.

3.14 Site Clean Up

- .1 During the planting operations, all sidewalks, streets, approaches, driveways and properties near or about the planting operations, shall be kept clean at all times by the Contractor.
- .2 All clay and in-situ material shall be removed from the Site by the Contractor by the end of the Working Day (if piled in the street or on the sidewalk) or within 48 hours (if piled on boulevards or in parks).
- .3 Upon completion of the Work, the Contractor shall immediately remove all excess material and debris from the Work Site and shall leave the Site in a clean and orderly manner.

3.15 Acceptance

- .1 Thirty (30) days after the planting has been completed, the Contract Administrator shall perform an inspection of plant material.
- .2 Plant material shall be accepted to start warranty when installation in accordance with the Drawings and Specifications is complete and there is no sign of wilting, chlorosis, pest infestation, transplant shock or any conditions deleterious to

longevity and appearance. Defective plants shall be replaced within thirty (30) days of notification to the Contract Administrator and shall be further maintained for a period of two years.

- .3 The Contractor is responsible for maintaining trees in accordance with Specification E9 from the date of planting to the end of the warranty period, unless otherwise specified.

4. MEASUREMENT AND PAYMENT

- .1 The supply and planting of street trees will be measured on a unit basis and paid for at the Contract Unit Price for the Items of Work listed below. The quantity to be paid for will be the total number of trees supplied and planted in accordance with this Specification, accepted and measured by the Contract Administrator.

Items of Work:

- (iii) [38mm cal. Green Ash]
- (iv) [25mm cal. American Elm]
(etc. to be determined by consultant)
- .2 Contract Unit Price includes [excavation, soil for backfill, mulch, staking, tree protection collar, 30 days maintenance ...] *to be completed by consultant*
- .3 Contract Unit Price does not include [tree vault, tree grate, tree guard, subdrain...] *to be completed by consultant.*

END OF SECTION

E8. TREE GRATES AND GUARDS

1. DESCRIPTION

1.1 General

- .1 This Specification covers the supply and installation of tree grates and tree guards.

1.2 Referenced Standard & Draft Construction Specifications

- .1 CW 3310 – Portland Cement Concrete Pavement Works
- .2 CW 3540 – Topsoil and Finish Grading for Establishment of Turf Areas
- .3 E1 – Silva Cells
- .4 E3 – Tree Vaults
- .5 E4 – Structural Soil
- .6 E7 – Tree Planting – Downtown and Regional Streets

1.3 Related Details

- .1 F1– Tree Planting using Silva Cells
- .2 F3 – Tree Planting in Tree Vault
- .3 F4 – Tree Planting using Structural Soil

2. MATERIALS

2.1 General

- .1 Submit shop drawings for tree grates and tree guards, in accordance with Specification CW 1110. Indicate dimensions, assembly, materials, finishes, anchorage and installation details.

2.2 Tree Grates

- .1 Size and style to suit project-specific conditions.
Consultant to name size, model and finish
- .2 All grates must have adjustable trunk opening to accommodate tree growth. Preferred maximum width of all other openings: 6 mm (1/4") to comply with Americans with Disabilities Act requirements.
- .3 Material and finish to be durable and low maintenance. Ductile iron or approved alternate.
- .4 Supply grate complete with matching corrosion-resistant frame unless otherwise directed by Contract Administrator.

- .5 Submit shop drawings. Indicate dimensions, sizes, assembly, material, finishes, anchorage and installation details.
- .6 Walkable Tree Grates – tree grates must comply with City of Winnipeg Accessibility Design Standards.

2.3 Tree Guards

- .1 Two-piece steel guards with continuous splash/silt guard at base, or approved alternate. Minimum 500mm inside diameter and optimal 1.2m height.
- .2 Welding in accordance with all applicable specifications and standards.
- .3 Finish to be one layer corrosion resistant, meeting SAE J2334 Scribe specifications. Autophoretic coating system (by Urban Park Site Furnishings, Steinbach, Manitoba, phone 1-800-775-0018, or approved alternate) and two layers of power coating meeting all applicable specifications and standards. Prior to application of autophoretic coating, metal must be cleaned using the eight (8) stage ICS cleaning process (<http://www.icscoating.com>). Finish must be applied to ensure that there is no rusting at holes, edges and welds.

2.4 Gasket

- .1 Where grate and guard are dissimilar metals, provide neoprene gasket or approved alternate to prevent galvanic corrosion.

3. CONSTRUCTION METHODS

3.1 General

- .1 Install grates and frames true and plumb, in accordance with manufacturer's written instructions.

3.2 Schedule

- .1 Coordinate order and delivery of corrosion-resistant frames to coincide with concrete pour.

3.3 Setting Tree Grate Frame

- .1 Where corrosion resistant frame is specified, assemble frame and grate and set assembly on concrete header (tree well) formwork. Adjust height and alignment of forms as required to match grate elevation and grade with adjacent paving elevation and grade.
- .2 Ensure concrete headers (tree wells) are located, sized and aligned to suit control joint pattern. Obtain approval of locations.
- .3 Install 10M rebar through lugs on the frame and support where indicated.

3.4 Tree Grates Without Frame

- .2 Where no corrosion resistant frame is specified, ensure tree well header is formed/fabricated so that grate is square to the header at matches the elevation and grade of adjacent paving.

- .3 Ensure concrete headers (tree wells) are located, sized and aligned to suit control joint pattern. Obtain approval of locations.

3.5 Concrete

- .1 Pour and finish concrete in accordance with Specification CW 3310. Do not remove tree grate until concrete is set up.

3.6 Installing Tree Guard

- .1 After tree is planted, install tree guard using approved hardware. Where mounting points are not provided on the grate, obtain approval from the Contract Administrator of proposed fastening method.

3.7 Protection

- .1 Cover open tree wells to prevent injury.
- .2 Protect installed tree wells, grates and guards from damage from subsequent construction operations. Time operations to minimize risk of damage.
- .3 Remove protection materials upon Substantial Performance of Work, or when risk of damage is no longer present.

4. MEASUREMENT AND PAYMENT

- .1 The supply and installation of tree grates and guards will be measured on a unit basis and paid for at the Contract Unit Price for the Items of Work listed below. The quantity to be paid for will be the total number of trees supplied and installed in accordance with this Specification, accepted and measured by the Contract Administrator.

Items of Work:

- (v) [Supply and Install 1500 x 1800 Metropolitan Series Tree Grate]
- (vi) [Supply and Install Tree Guard]
(etc. to be determined by consultant)

END OF SECTION

E9. LONG TERM MAINTENANCE OF NEW TREE PLANTINGS

1. DESCRIPTION

1.1 General

- .1 The Contractor shall be responsible for the maintenance of all plant material for a period of two (2) years from date of acceptance. Refer to Specification E7 for acceptance requirements.
- .2 The Contractor shall furnish all labour, materials, equipment and services necessary to perform ongoing care of the plant material, which shall include but not be limited to:
 - (a) Mulching
 - (b) Watering
 - (c) Weed Control

2. MATERIALS

2.1 Mulch

- .1 Refer to Specification E7: Tree Planting – Downtown and Regional Streets.
- .2 Or approved alternate.

2.2 Water

- .1 Use potable water, free from impurities injurious to vegetation.

3. METHODS

3.1 General

- .1 Program the timing of operations to plant growth, weather conditions and use of the Site.
- .2 Do each operation continuously and complete within a reasonable time period.
- .3 Store equipment and materials off-site.
- .4 Add additional mulch as required to maintain minimum constant depth of mulch.
- .5 Clean up edges and contain mulch within the designated area.

3.2 Watering

- .1 Watering shall be done every seven to fourteen days between May and October or as frequently as necessary (compensating appropriately for weather) to sustain vigorous plant growth.
- .2 Water slowly, using a low pressure open flow nozzle and hose, to ensure that water does not run away from the root zone and so the top 300 mm of soil around the root system of the tree is well saturated. The water stream must not gouge out a hole in the soil or mulch.
- .3 Water approximately 8-10 times during the growing season to provide 40 litres of water per 25 mm calliper.
- .4 The Contractor shall recognize that watering requirements of trees are dependant upon on a number of variables such as tree species, soil type, planting date, and weather including precipitation. The watering requirements stipulated herein are a minimum standard and shall be followed unless otherwise directed by the Contract Administrator or his designate.
- .5 Apply an end-of season watering for all trees, regardless of when planted, that shall be completed after temperatures fall below freezing to ensure adequate moisture in root zone at freeze-up.

3.3 Weeding

- .1 Maintain surface of tree pit by hand weeding.
- .2 Do not allow weeds to establish for a period longer than two (2) weeks.
- .3 Do not use any herbicides for weed control near trees unless authorized by the Contract Administrator.

3.4 Tree Protection/Support

- .1 Ensure trunk protection collars and tree supports are maintained in good condition, serving their intended function and posing no threat to public safety.
- .2 The trunk protection collars shall be left on trees after the maintenance period is completed.
- .3 Tree supports shall be removed or left in place at the end of the warranty period as directed by the Contract Administrator.

3.5 Reporting

- .1 The Contractor must inform the Contract Administrator of watering progress and schedule by 9:00 AM each day of watering.
- .2 The Contractor must inform the Contract Administrator immediately of any equipment breakdown or delay in watering and maintenance. Once a watering cycle is completed, submit a log-sheet to the Contract Administrator identifying the following:

- (a) the location where maintenance Work is carried out; and
- (b) preventative or corrective measures required which are outside Contractors' responsibility.

3.6 Site Safety and Traffic Control

- .1 Site Safety and Traffic Control measures shall be carried out in all areas on or adjacent to roadways in accordance with Specification E7.

3.7 Damage to Property

- .1 The Contractor shall take every precaution not to damage, injure or mark any existing structures or landscaping on the street allowance or adjacent properties.
- .2 Should any damage be caused by the Contractor, their employees or equipment, it shall be restored or replaced at the Contractor's expense and to the satisfaction of the Contract Administrator. This applies even if damage results from work done in the process of correcting deficiencies.

3.8 Tree Mortality – City Supplied Trees

- .1 If a City-supplied tree dies and the Contractor has not been submitting the regular maintenance records in accordance with this contract document, then the cost to supply, plant and maintain a replacement tree as originally indicated in the contract document, shall be at the sole expense of the Contractor.
- .2 If a City-supplied tree dies and the Contract Administrator believes that the tree has been maintained in accordance to this Specification, that tree will be replaced by the City and added to the Contract at the originally specified bid price to be planted and maintained by the Contractor in accordance with this specification.
- .3 Replacement trees shall receive 2 years maintenance as outlined in the contract document, from the date of replacement.
- .4 Inspections of replacement trees will be conducted by City of Winnipeg staff.

3.9 Tree Mortality – Contractor Supplied Trees

- .1 If a Contractor-supplied trees dies and the Contractor has not been submitting the regular maintenance records in accordance with these specifications, then the cost to supply, plant and maintain a replacement tree as originally indicated in the contract document, shall be at the sole expense of the Contractor.
- .2 If a Contractor-supplied tree dies and the Contractor has been submitting the regular maintenance records in accordance with these specifications, that tree will be added to the Contract at the originally specified bid price to be supplied, planted and maintained by the Contractor in accordance to this specification.
- .3 Replacement trees shall receive 2 years maintenance as outlined in the contract document, from the date of replacement.
- .4 Inspections of replacement trees will be conducted by City of Winnipeg staff.

4. MEASUREMENT AND PAYMENT

- .1 Landscape Maintenance shall be paid for on an annual lump sum basis for the Items of Work listed below, measured as specified herein, which price shall be payment in full for performing all operations herein described and all other items incidental to the Work included in this Specification.

Items of Work:

- (i) Landscape Maintenance Year 1
- (ii) Landscape Maintenance Year 2
(etc. to be determined by consultant)

END OF SECTION

Part 2: Drawings

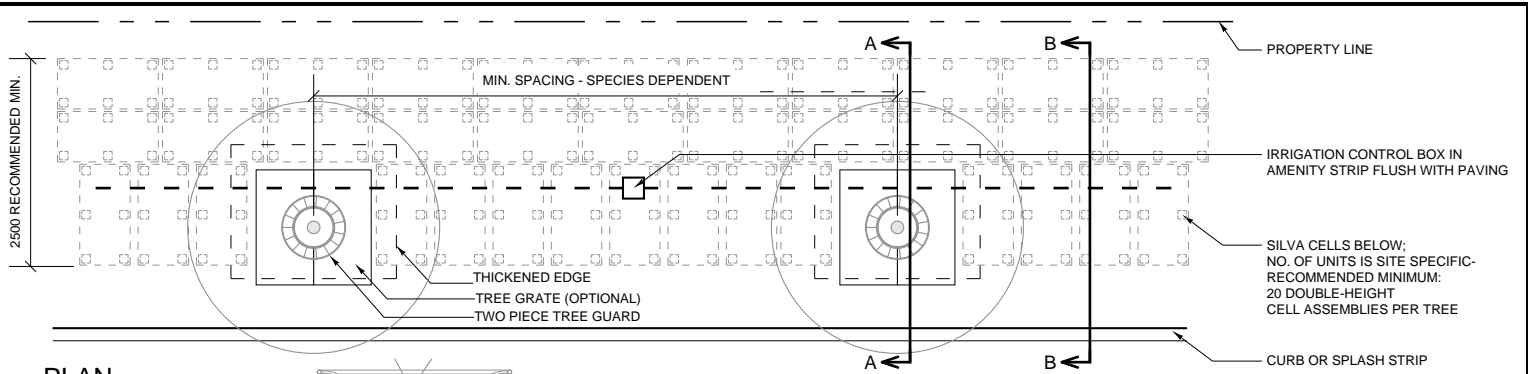

PLAN

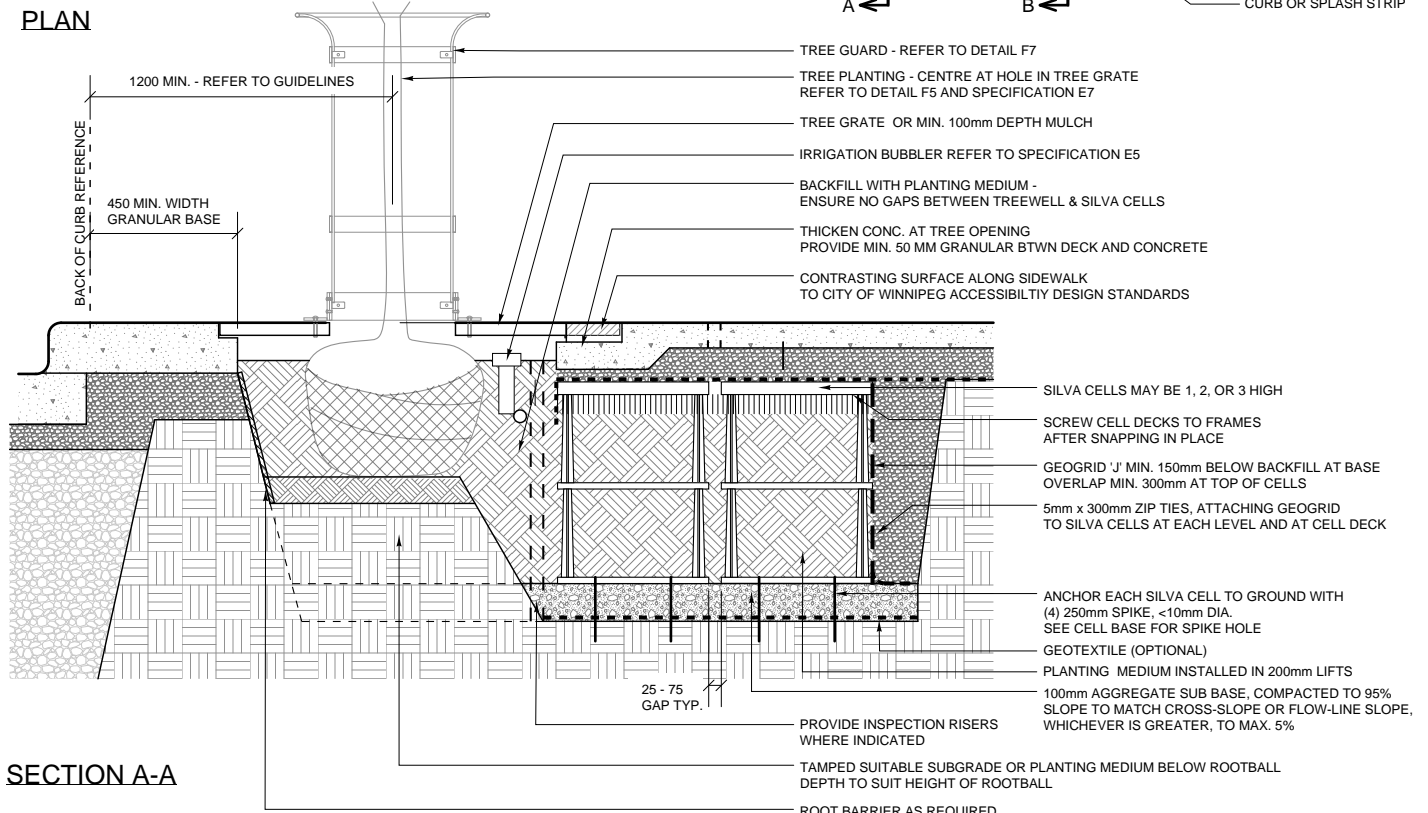

SECTION A-A

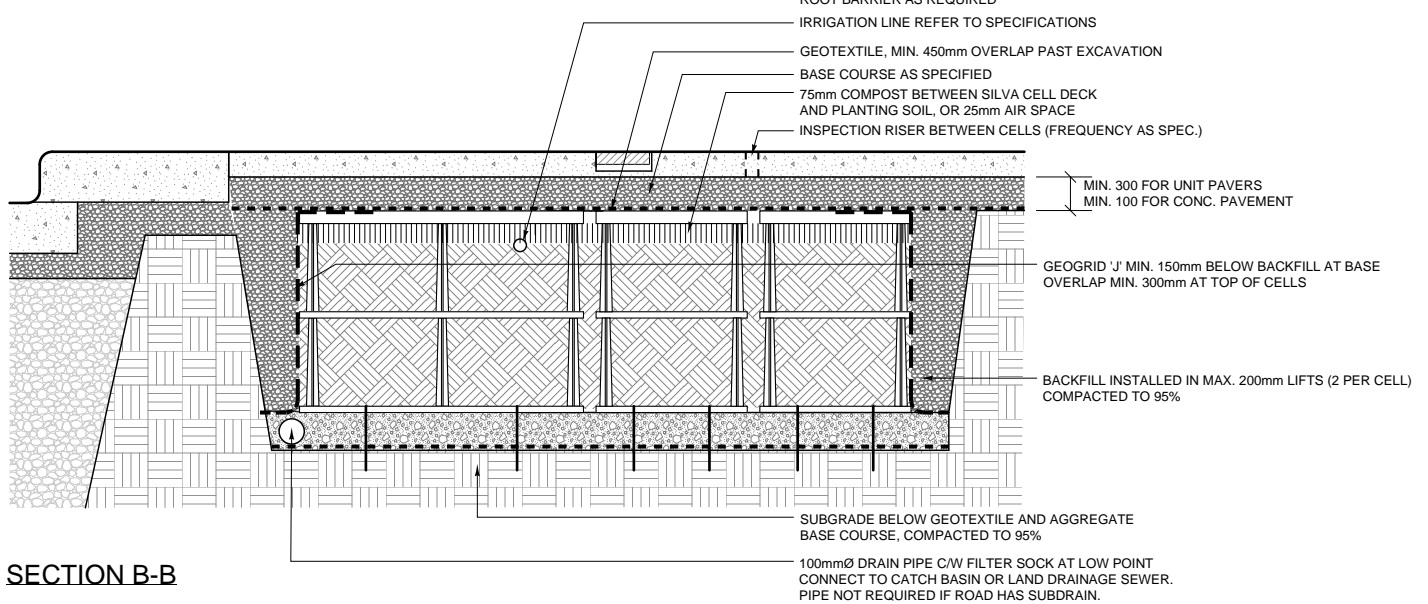

SECTION B-B

DRAFT

TREE PLANTING USING SILVA CELLS

DATE:
13-03-09

SCALE:
N.T.S.

DETAIL NO. **F1**

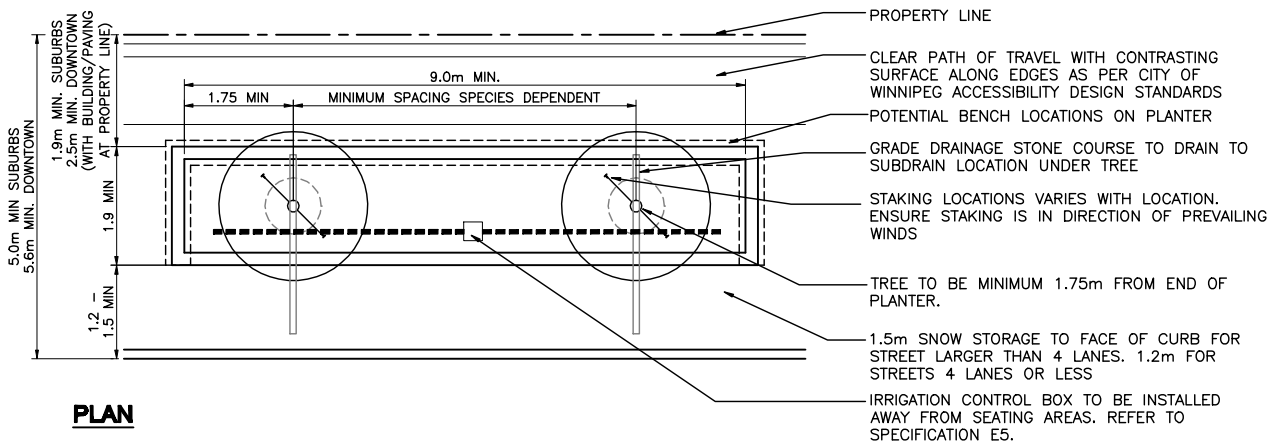

PLAN

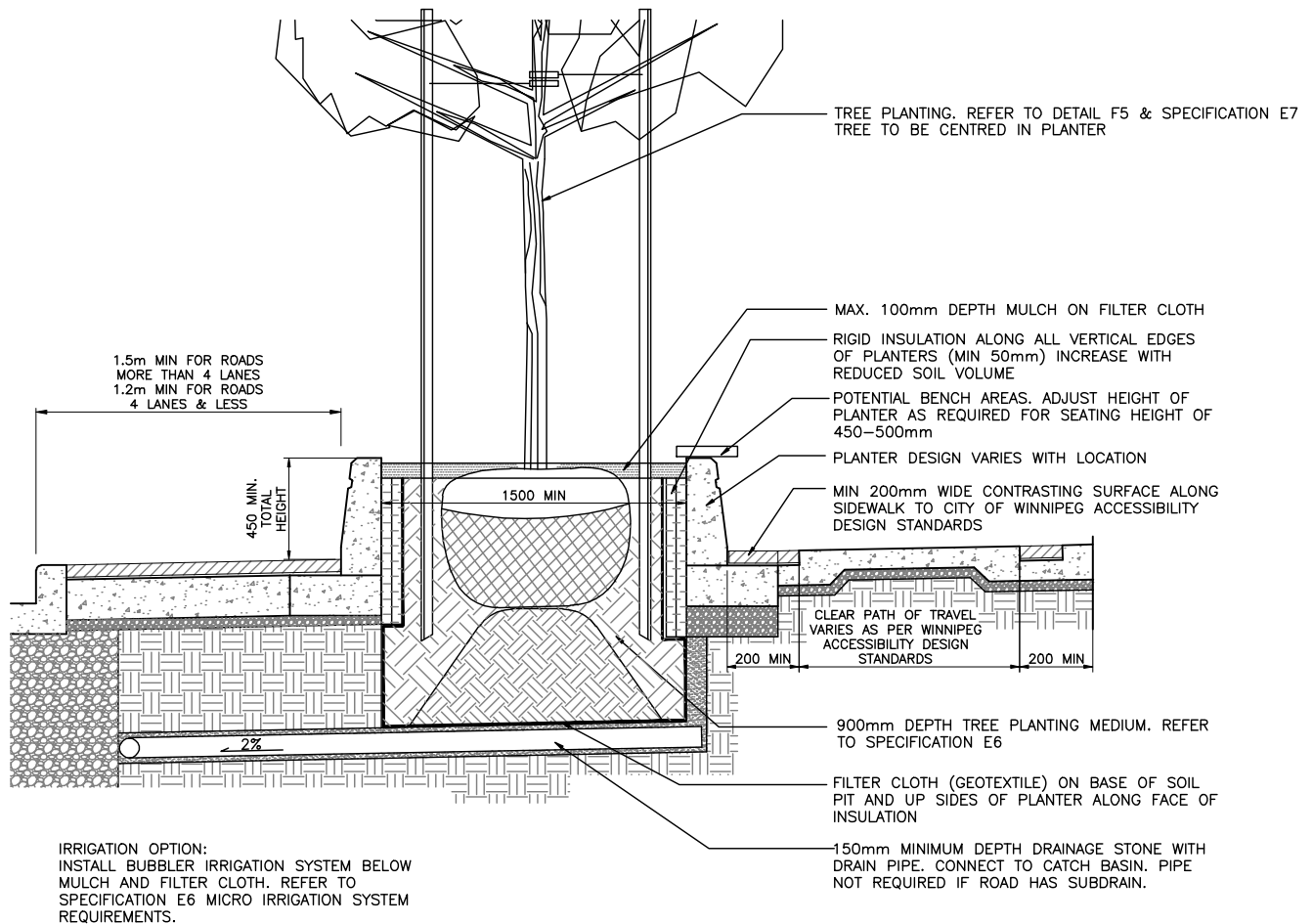

SECTION

RAISED CONCRETE PLANTER TREE PLANTING FOR REGIONAL STREETS

THIS DETAIL TO BE READ IN CONJUNCTION WITH SPECIFICATION
E2 RAISED TREE PLANTERS

DATE: 24-03-08	SCALE: N.T.S.
DETAIL NO.:	
F2	

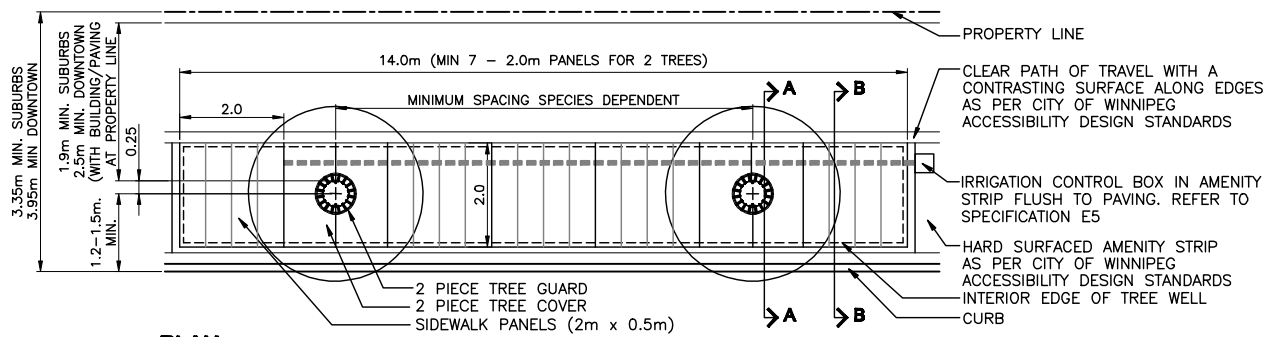

PLAN

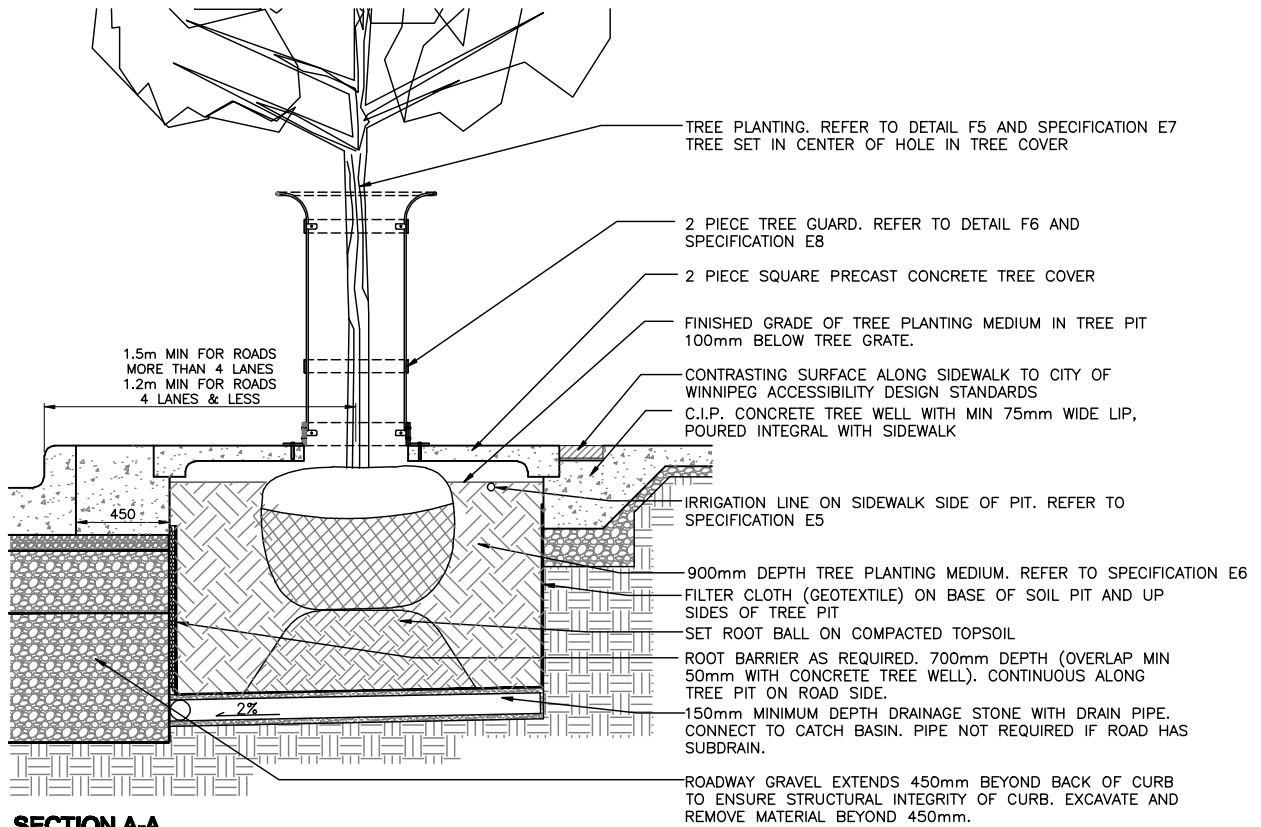

SECTION A-A

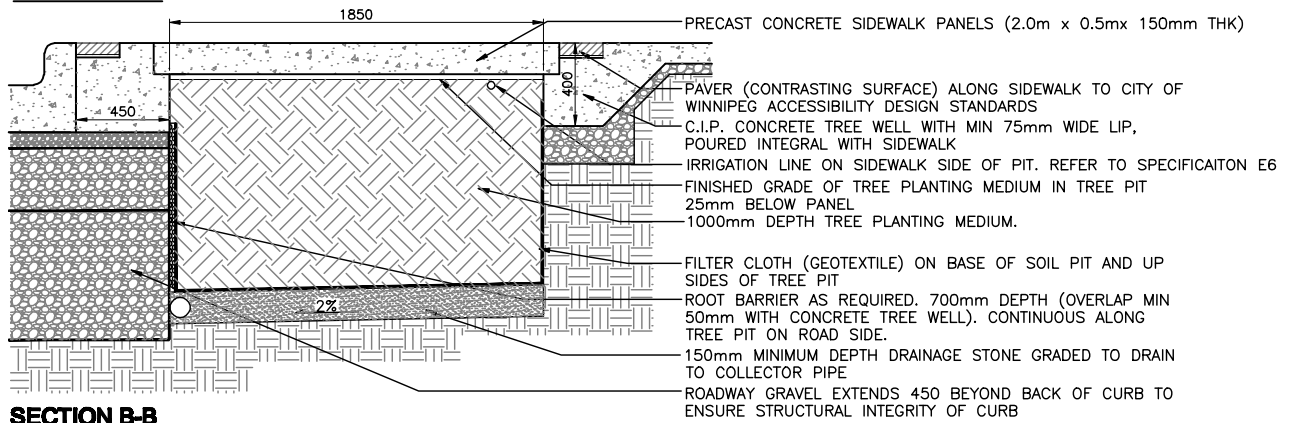

SECTION B-B

TREE VAULT TREE PLANTING FOR DOWNTOWN AND REGIONAL STREETS

THIS DETAIL TO BE READ IN CONJUNCTION WITH SPECIFICATION
E3 TREE VAULTS

DATE:

24-03-08

SCALE:

N.T.S.

DETAIL NO.:

F3

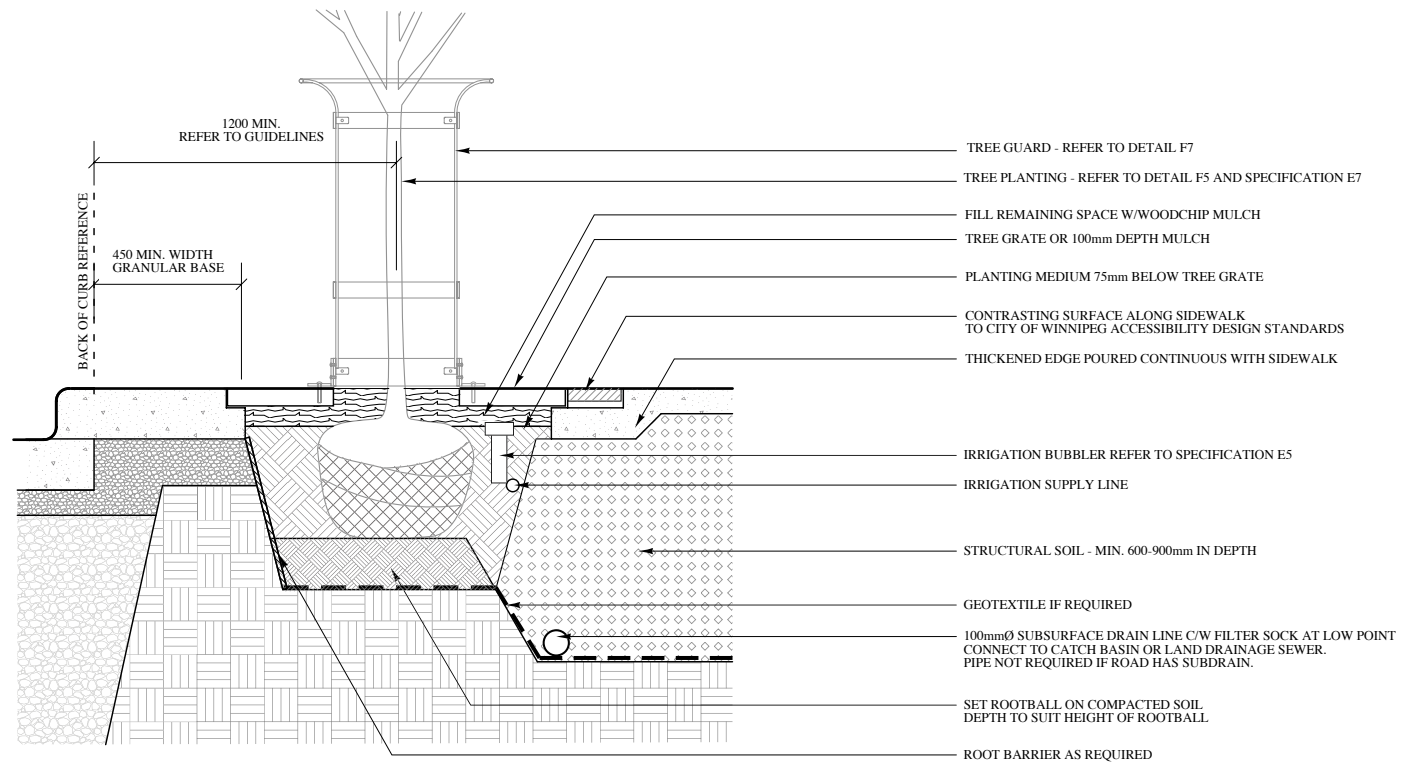
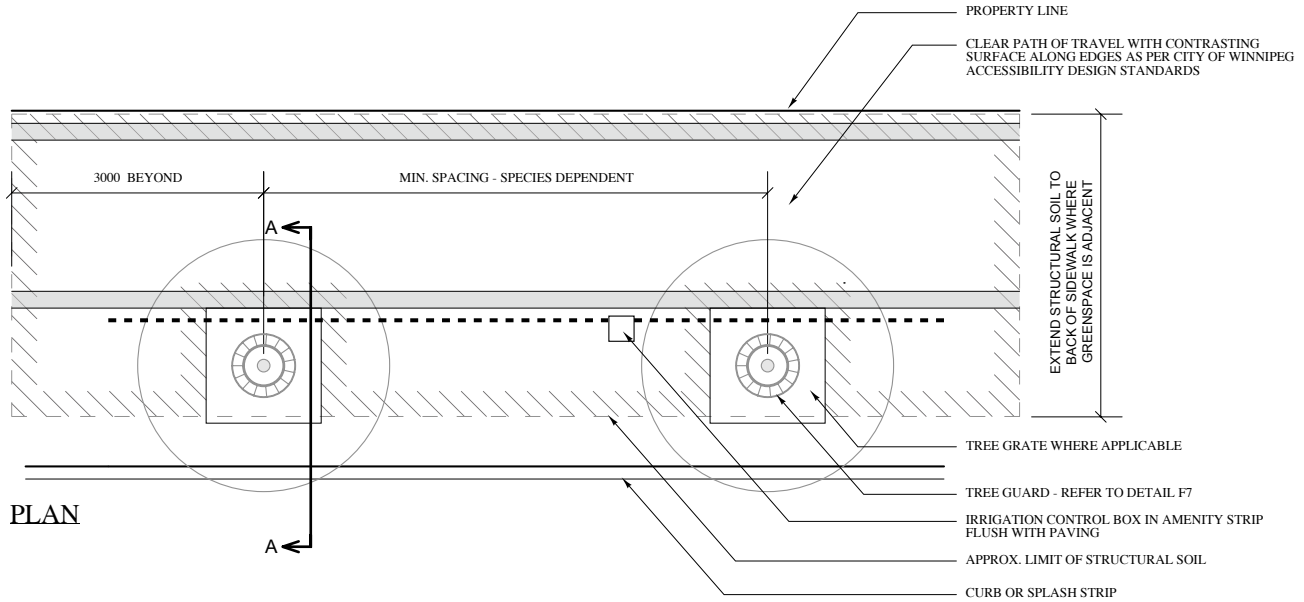

DRAFT

TREE PLANTING USING STRUCTURAL SOIL

DATE:

22-12-08

SCALE:

N.T.S.

DETAIL NO:

F4

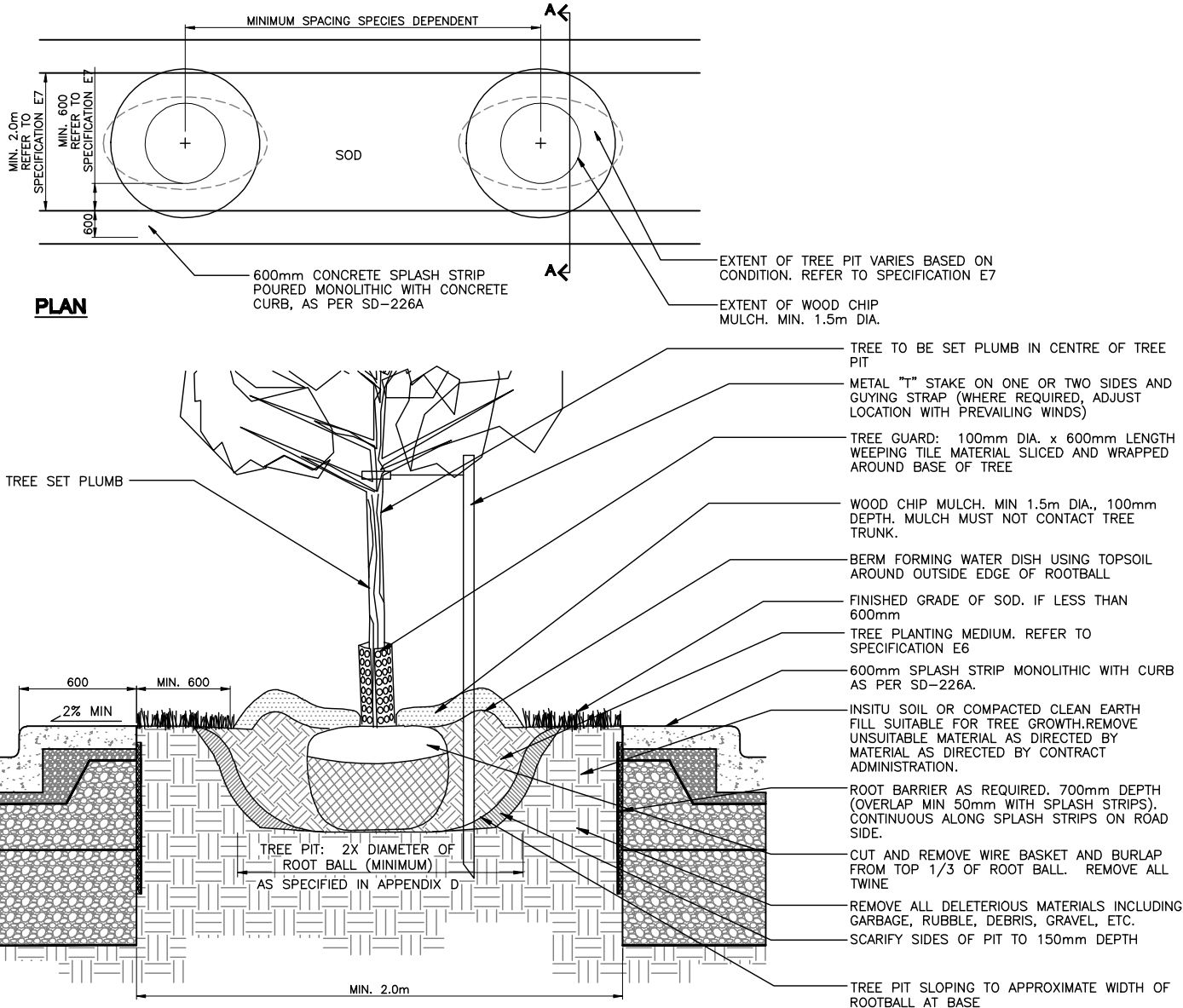

PLAN

- EXTENT OF TREE PIT VARIES BASED ON CONDITION. REFER TO SPECIFICATION E7
- EXTENT OF WOOD CHIP MULCH. MIN. 1.5m DIA.
- TREE TO BE SET PLUMB IN CENTRE OF TREE PIT
- METAL "T" STAKE ON ONE OR TWO SIDES AND GUYING STRAP (WHERE REQUIRED, ADJUST LOCATION WITH PREVAILING WINDS)
- TREE GUARD: 100mm DIA. x 600mm LENGTH WEEPING TILE MATERIAL SLICED AND WRAPPED AROUND BASE OF TREE
- WOOD CHIP MULCH. MIN 1.5m DIA., 100mm DEPTH. MULCH MUST NOT CONTACT TREE TRUNK.
- BERM FORMING WATER DISH USING TOPSOIL AROUND OUTSIDE EDGE OF ROOTBALL
- FINISHED GRADE OF SOD. IF LESS THAN 600mm
- TREE PLANTING MEDIUM. REFER TO SPECIFICATION E6
- 600mm SPLASH STRIP MONOLITHIC WITH CURB AS PER SD-226A.
- INSITU SOIL OR COMPACTED CLEAN EARTH FILL SUITABLE FOR TREE GROWTH.REMOVE UNSUITABLE MATERIAL AS DIRECTED BY MATERIAL AS DIRECTED BY CONTRACT ADMINISTRATION.
- ROOT BARRIER AS REQUIRED. 700mm DEPTH (OVERLAP MIN 50mm WITH SPLASH STRIPS). CONTINUOUS ALONG SPLASH STRIPS ON ROAD SIDE.
- CUT AND REMOVE WIRE BASKET AND BURLAP FROM TOP 1/3 OF ROOT BALL. REMOVE ALL TWINE
- REMOVE ALL DELETERIOUS MATERIALS INCLUDING GARBAGE, RUBBLE, DEBRIS, GRAVEL, ETC.
- SCARIFY SIDES OF PIT TO 150mm DEPTH
- TREE PIT SLOPING TO APPROXIMATE WIDTH OF ROOTBALL AT BASE

TURF BOULEVARDS / MEDIANS TREE PLANTING FOR REGIONAL STREETS

THIS DETAIL TO BE READ IN CONJUNCTION WITH SPECIFICATION
E7 TREE PLANTING - DOWNTOWN AND REGIONAL STREETS

DATE: 24-03-08	SCALE: N.T.S.
DETAIL NO.:	
F5	

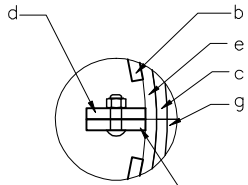

UNIT IS TO BE FORMED IN TWO PIECES & JOINED AT THIS POINT.

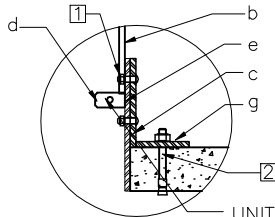

UNIT IS TO BE FORMED IN TWO PIECES & JOINED AT THIS POINT.

PARTS SCHEDULE			
ITEM	QTY	DESCRIPTION	LENGTH
	1	TREE GUARD	
a	2	5/8"(16mm)Ø ROUND BAR	46 3/4"(1187mm)
b	16	3/8"(9mm)x 1"(25mm) FLAT BAR SEE DETAIL 1/A3	46 1/2"(1181mm)
c	2	3/8"(9mm)x 4"(102mm) FLAT BAR SEE DETAIL 1/A2	30 3/8"(772mm)
d	8	3/8"(9mm)x 1"(25mm) FLAT BAR SEE DETAIL 2/A2	2" (51mm)
e	2	3/8"(9mm)x 7"(178mm) PLATE SEE DETAIL 2-3/A3	30 3/8"(772mm)
f	2	3/8"(9mm)x 2"(51mm) FLAT BAR SEE DETAIL 1/A4	31 1/2"(800mm)
g	2	3/8"(9mm)x 13 3/8"(352mm) PLATE SEE DETAIL 1-2/A4	27 1/8"(703mm)

BOLT SCHEDULE			
ITEM	QTY	DESCRIPTION	LENGTH
1	16	5/16"(8mm)Ø TAMPER/RUST PROOF BOLT w/ NUT	1 1/4"(32mm)
2	2	3/4"(12mm)Ø EPOXIED BOLT	3 3/4"(95mm)

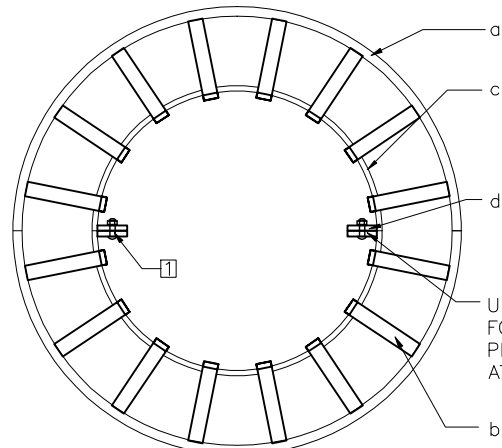
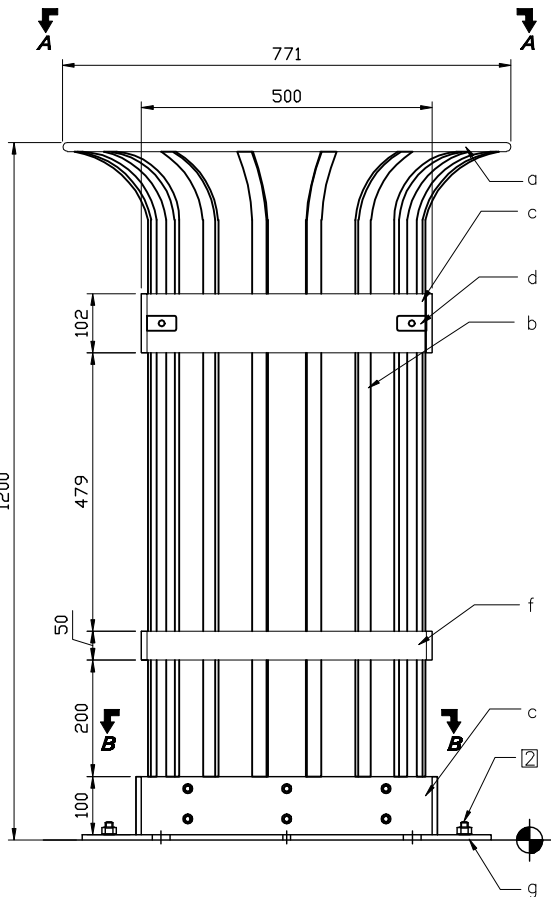

UNIT IS TO BE FORMED IN TWO PIECES & JOINED AT THIS POINT.

SECTION A-A

SCALE: 1:10

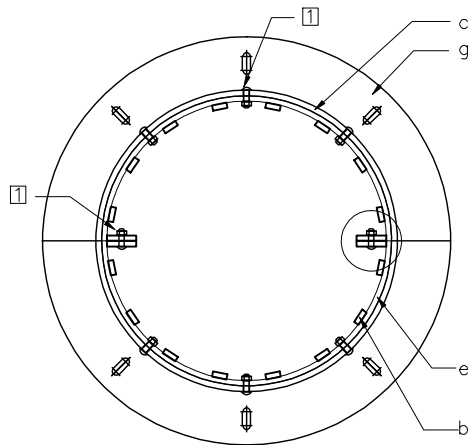

SECTION B-B

SCALE: 1:10

TREE GUARD

THIS DETAIL TO BE READ IN CONJUNCTION WITH SPECIFICATION E8 TREE GRATES AND GUARDS

DATE:

24-03-08

SCALE:

N.T.S.

DETAIL NO.:

F6

Appendix B

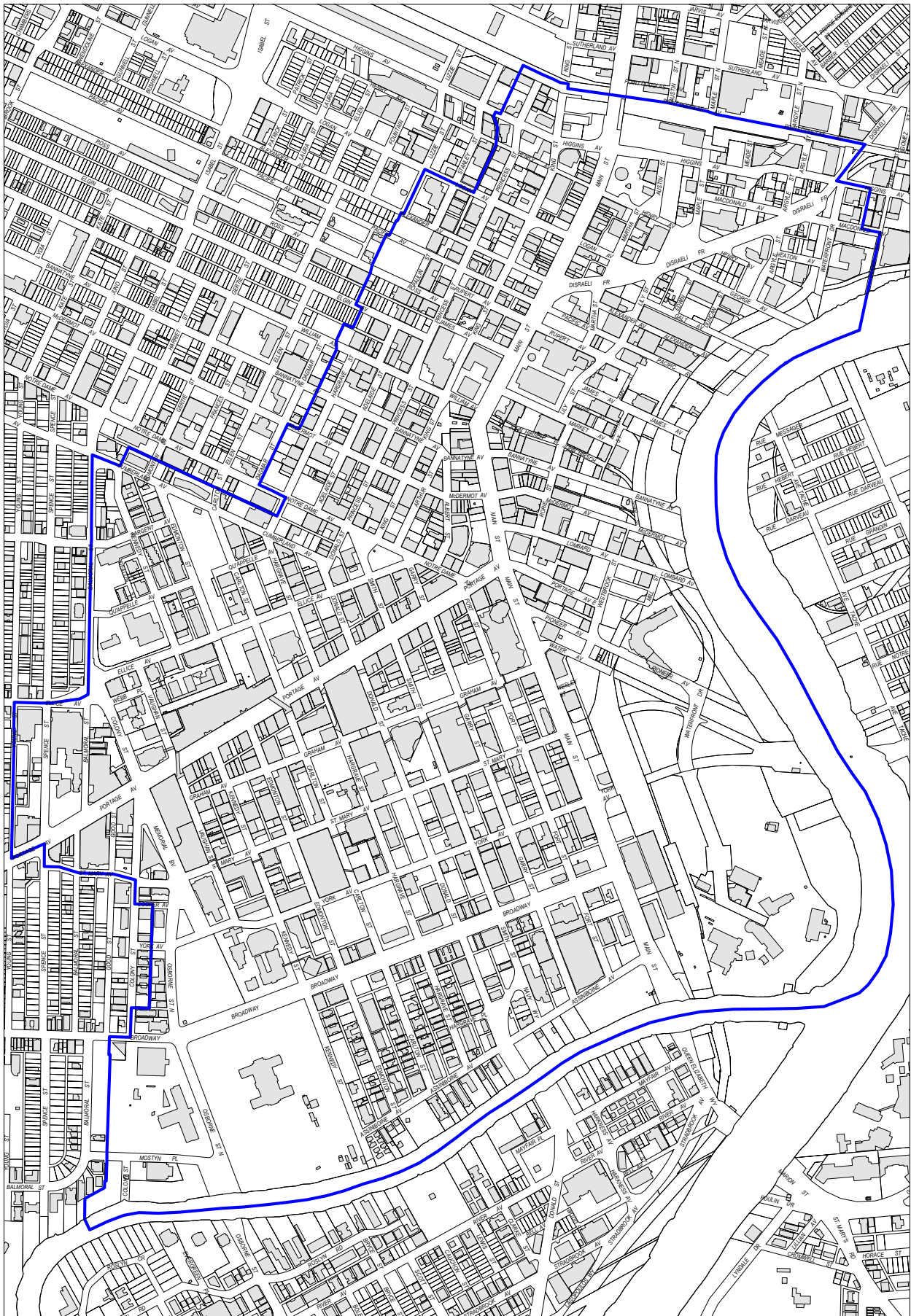

**CITY OF WINNIPEG
PLANNING, PROPERTY & DEVELOPMENT DEPT.
LAND INFORMATION SERVICES**

NOTE:
Information displayed hereon has been compiled or computed
from a variety of sources and should be used as a general
guide only. No warranty is expressed or implied regarding
the accuracy of such information.

— CENTREVENTURE MANDATE AREA



Winnipeg
SCALE 1:4300

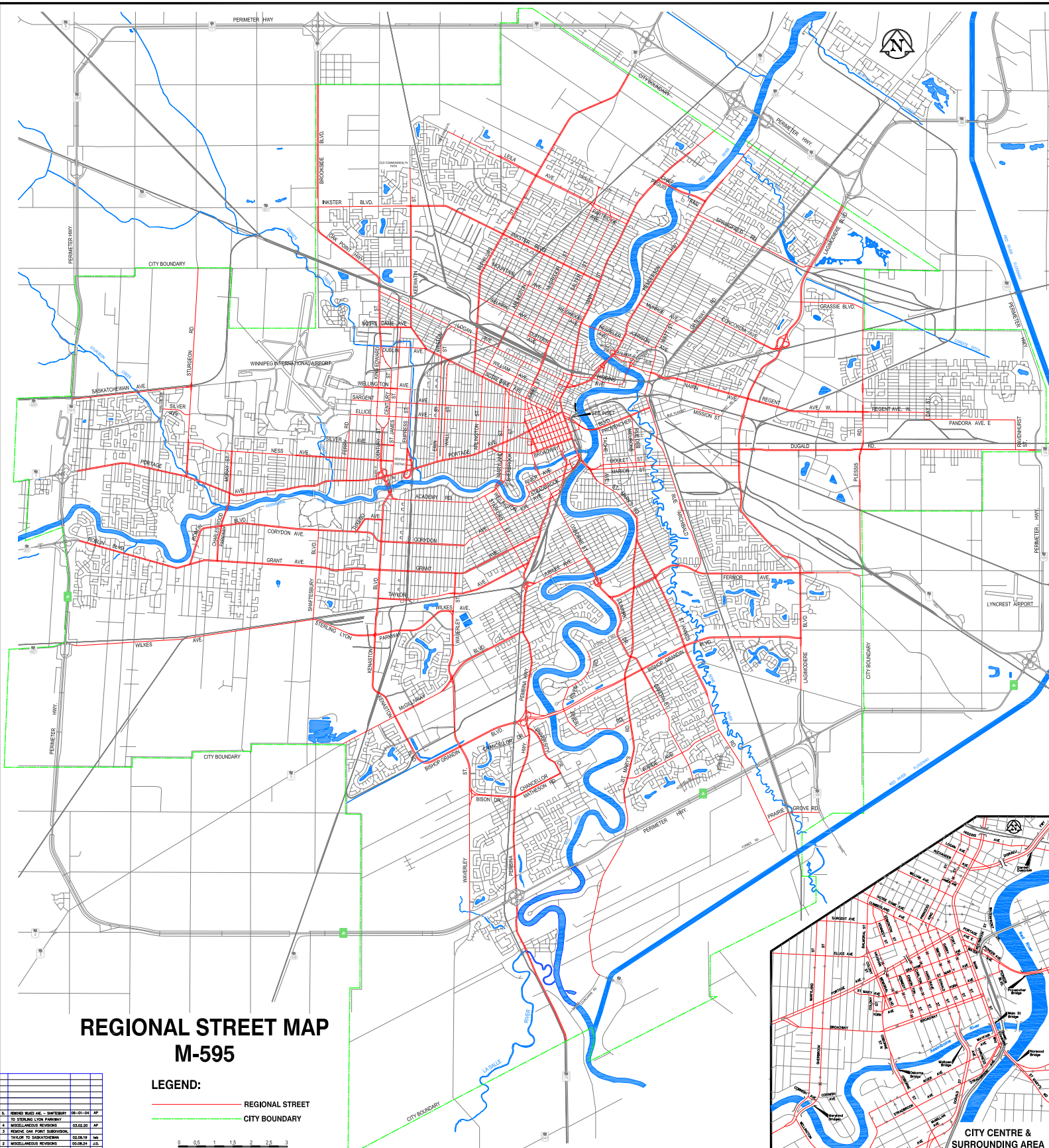

REGIONAL STREET MAP M-595

LEGEND:
— REGIONAL STREET
— CITY BOUNDARY



NO.	REVISION/ADD	DATE	BY
6	REMOVED BRUCE AVE - SHAWENAY TO STURGEON LYON PARKWAY	20-01-24	SP
4	WINDLINGHAM REVISIONS	03.03.20	SP
3	REMOVED OAK POINT SUBDIVISION		
2	TALON TO SUBSTITUTIONS	02.08.19	MS
1	WINDLINGHAM REVISIONS	03.08.14	MS
1	RIVER RD ADDED	02.08.13	MS
MS	REVISIONS	DATE	BY

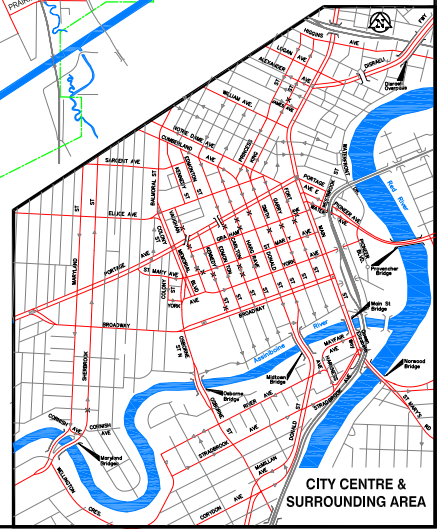

CITY CENTRE & SURROUNDING AREA

Appendix C

4.3 OTHER AMENITIES

4.3.17 STREETScape

RATIONALE

Clear paths of travel are important to all individuals using pathways. Streetscape elements such as newspaper boxes, trash bins, outdoor patios and bus shelters present a barrier to all pedestrians, especially those that require additional space for use of wheelchairs, scooters, strollers or delivery carts. For persons with a visual impairment, unidentified obstructions within pathways can present a hazard.

Outdoor patios are increasingly encroaching on pedestrian pathways and ideally should incorporate features such as railings, indicator and pavement markings, that are easily distinguished both visually and by cane.

The efficient and thorough removal of snow and ice are also essential to outdoor pathways. Negotiating a wheelchair or stroller through a snow covered path is exceptionally difficult. Icy surfaces are hazardous to all pedestrians, especially individuals such as senior citizens that may not be sure-footed.

Benches can provide a resting place for an individual with difficulty in walking distances. Such furniture should incorporate strong colour contrasts and be located off pathways, to minimize its potential as an obstruction to pedestrians.

APPLICATION

Street elements, including but not limited to, waste receptacles, light standards, signs, planters, mail

boxes, vending machines, benches, traffic signals, red-light cameras and utility boxes contained within a public right-of-way, shall comply with this section, including street elements that are located inside or outside of facilities.

All waste receptacles, except those located in unpaved areas of parks, wilderness, beach or unpaved picnic areas or large industrial containers, shall be accessible to persons using wheelchairs or other mobility devices.

Provide waste receptacles in public rights-of-way for guide dog users, as well as for other pet owners.

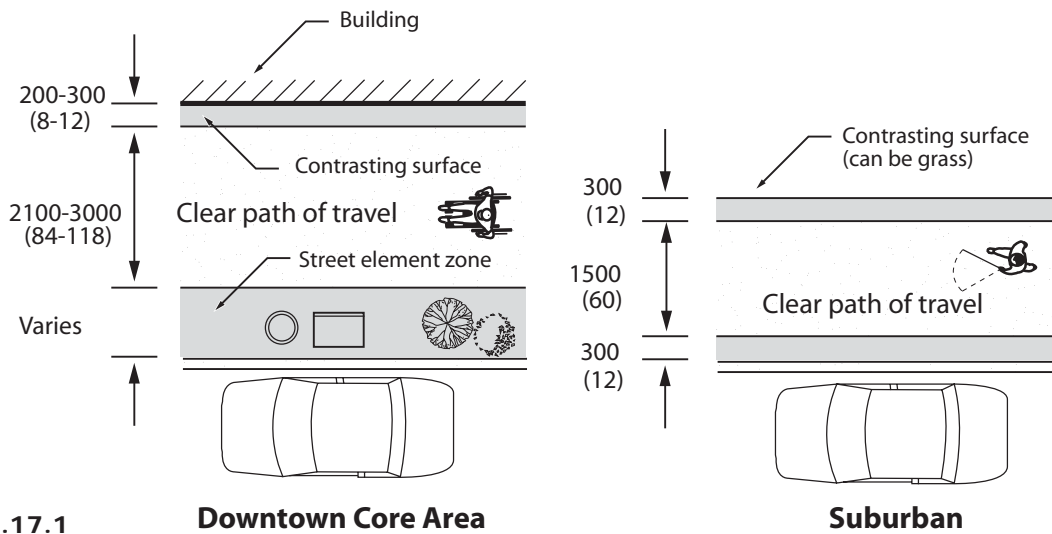

Figure 4.3.17.1
Typical Streetscape Configurations

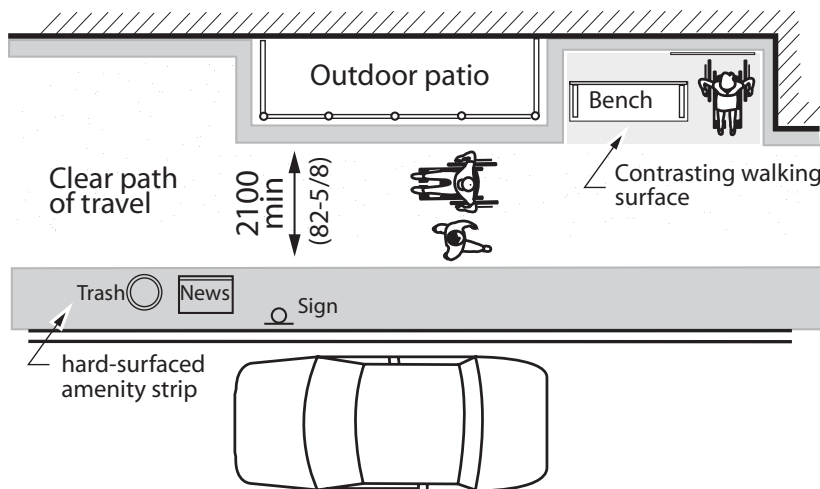

Figure 4.3.17.2
Downtown Core Area Streetscape

4.3.17 STREETSCAPE

4.3 OTHER AMENITIES

DESIGN REQUIREMENTS

Where sidewalks are provided along *public rights-of-way*, within the Winnipeg Downtown Core Area, an *accessible route* at least 2100 mm (82-5/8 in.) wide shall be maintained along the sidewalk.

Where sidewalks are provided along *public rights-of-way*, outside the Winnipeg Downtown Core Area, an *accessible route* at least 1500 mm (59 in.) wide shall be maintained along the sidewalk.

The *accessible routes* along *public rights-of-way* must be identified using a minimum 300 mm (11-3/4 in.) wide continuous *indicator surface* along each side of the *accessible route*.

Clearances along *accessible routes* along *public rights-of-way* must comply with 4.1.3.

Street elements shall

- not reduce the required width of the *accessible route*;
- be cane-detectable, in compliance with 4.1.3;

- be consistently located to one side of the *accessible route*, entirely within an amenity strip that is hard-surfaced, at least 600 mm (23-1/2 in.) wide, and is identified using a *indicator surface*; and
- be securely mounted within an amenity strip, minimum 600 mm (23-5/8 in.) wide, located adjoining walkways, paths, sidewalks and other *accessible routes*.

Street elements shall incorporate pronounced *colour contrast* to differentiate it from the surrounding environment.

Waste receptacles and recycling bins shall be large enough to contain the anticipated amount of waste, so that overflows do not cause a tripping hazard.

Waste receptacles and recycling bins in *accessible* open areas, such as *parks*, wilderness areas, beaches or picnic areas, shall be mounted on firm, level pads adjacent to the path or sidewalk (but not directly beside seating areas).

Waste receptacles and recycling bins shall be clearly identified by suitable lettering, in compliance with the relevant parts of 4.4.7.

Where lids or openings are provided on waste receptacles and recycling bins, they shall be mounted no higher than 1060 mm (42 in.) above the adjacent floor or ground surface. Opening mechanisms shall comply with 4.4.2.

On street mailboxes and community mailboxes shall

- be located immediately adjacent to an *accessible route*;
- incorporate a *clear area* at least 760 mm (30 in.) wide x 1370 mm (54 in.) long in front of usable parts;
- where provided, have slots for posting mail located to be reachable from a seated position;
- where provided, have at least 10%, but no less than one, mailbox for collecting mail, located to be reachable from a seated position;
- have operating mechanisms in compliance with 4.4.2; and
- be kept *clear* of snow.

RELATED SECTIONS

- 4.1.1 Space and Reach Requirements
- 4.1.2 Ground and Floor Surfaces
- 4.1.3 Protruding and Overhead Objects
- 4.1.4 Accessible Routes, Paths and Corridors
- 4.1.6 Doors
- 4.1.10 Curb Ramps
- 4.3.1 Drinking Fountains
- 4.3.11 Balconies, Porches, Terraces and Patios
- 4.3.12 Parking
- 4.3.13 Passenger Loading Zones
- 4.3.15 Benches
- 4.3.16 Picnic Tables
- 4.3.18 Traffic Signal Poles
- 4.3.18 Dog Relief Areas
- 4.4.4 Vending and Ticketing Machines
- 4.4.5 Public Telephones
- 4.4.7 Signage
- 4.4.8 Detectable Warning Surfaces
- 4.4.13 Lighting
- 4.4.14 Materials and Finishes
- 4.4.15 Texture and Colour

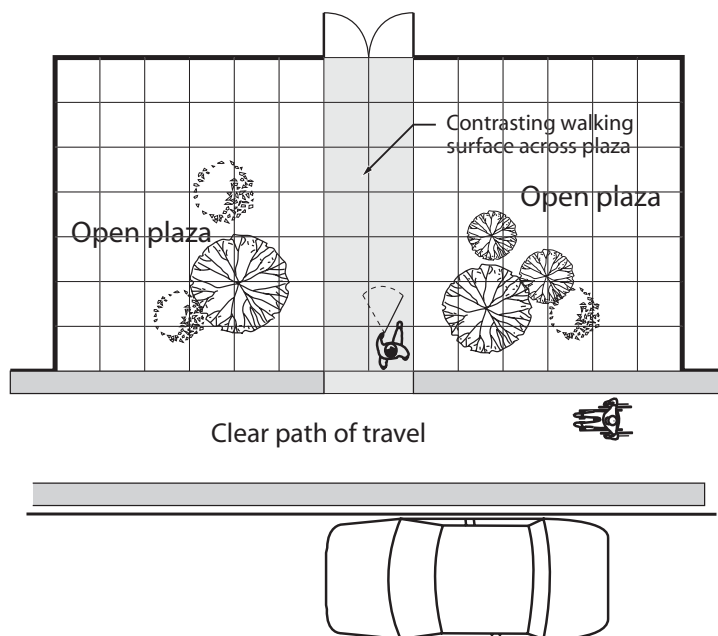

Figure 4.3.17.3
Pathway across Open Plaza

Appendix D

Specifications – Deciduous Trees

Relationship between caliper (measured 300 mm above ground level), overall height (not exceeding the upper limit of the range), branching height, minimum number of branches in head and minimum root spread.

CALIPER	ACCEPTABLE RANGE OF OVERALL HEIGHT	MINIMUM BRANCHING HEIGHT	MINIMUM NO. OF BRANCHES	MINIMUM ROOT SPREAD
20 mm	1800 – 2400 mm	1500 mm	3	400 mm
25 mm	1800 – 2400 mm	1500 mm	4	450 mm
25 mm	2400 – 3000 mm	1700 mm	4	450 mm
30 mm	2400 – 3000 mm	1700 mm	6	500 mm
40 mm	3000 – 3700 mm	1800 mm	8	550 mm
45 mm	3000 – 3700 mm	1800 mm	9	600 mm
50 mm	3700 – 4600 mm	2000 mm	10	650 mm
60 mm	3700 – 4600 mm	2000 mm	12	700 mm
75 mm	3700 – 4600 mm	2000 mm	14	800 mm
90 mm	4600 – 5500 mm	2000 mm	15	1000 mm

Note: Caliper shall be considered minimum measurements.